



TRADE PACKAGES

Pre-engineered packages for a broad range of trades.



CHOICE

A range of steel and aluminum packages are available for each vehicle.



TRADE SPECIFIC

Packages are created with the specific trades in mind. Optimized for maximum productivity.



PERFECT FIT

Engineered to optimize space. Layout designed to ensure that all tools are well within reach.

TRADE PACKAGES

BOX TRUCK, STEP VAN & TRAILER P. 54

CHEVROLET

EXPRESS P. 61

FORD

TRANSIT P. 68

TRANSIT CONNECT P. 82

GMC

SAVANA P. 89

MERCEDES-BENZ

METRIS P. 96

SPRINTER P. 103

RAM

PROMASTER P. 114

PROMASTER CITY P. 121

Get more out of your work van: Ranger Design packages are designed specifically with your trade in mind. Our aim is to ensure that your most frequently used tools and equipment are well within reach.

Do you see a way that we can improve our packages? We appreciate your feedback! Contact our customer service team at **1-800-565-5321**.



BOX TRUCK STEP VAN & TRAILER



PACKAGES

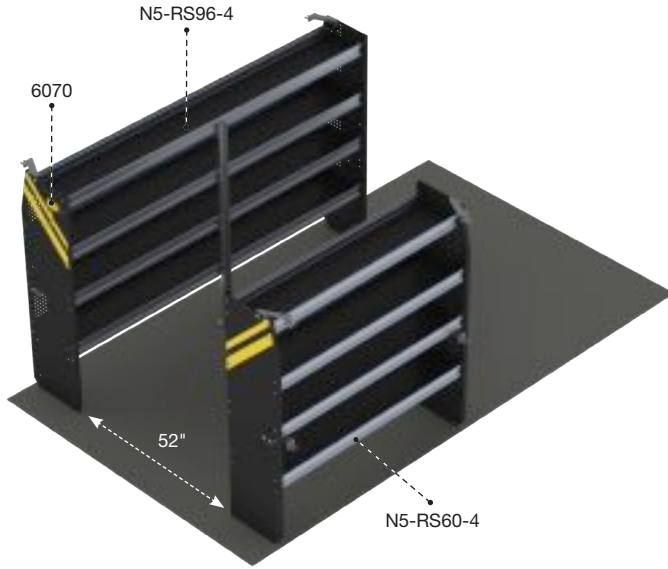

BTS-10 CONTRACTOR

| | | |
|---------|-----------|-----------|
| Steel | Short 10+ | High Roof |
| 211 lbs | 2.8 hrs | Yes |

| Qty | Part | Description |
|-----|-----------|--------------------------------------------|
| 1 | 6070 | 6" Hook, 3" opening, painted |
| 1 | N5-RS60-4 | Steel shelving unit, 14" D x 60" W x 62" H |
| 1 | N5-RS96-4 | Steel shelving unit, 14" D x 96" W x 62" H |

Aisle space calculated for this package is based on an 84" wide box.

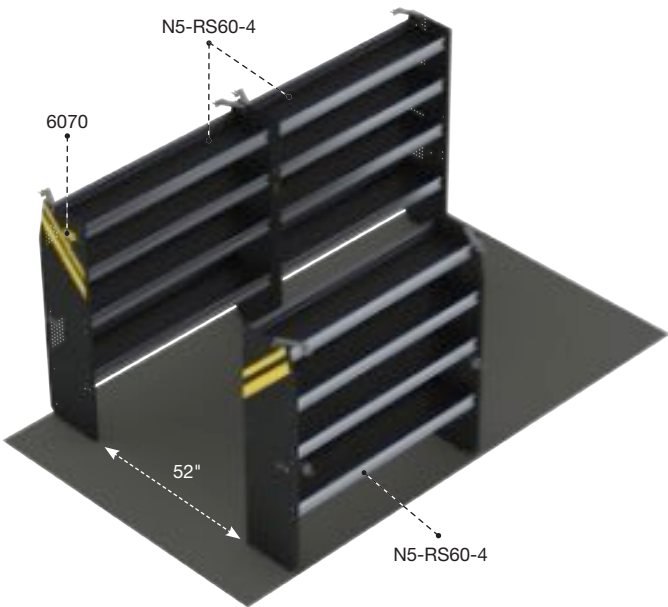

BTL-10 CONTRACTOR

| | | |
|---------|----------|-----------|
| Steel | Long 14+ | High Roof |
| 266 lbs | 3.8 hrs | Yes |

| Qty | Part | Description |
|-----|-----------|--------------------------------------------|
| 1 | 6070 | 6" Hook, 3" opening, painted |
| 3 | N5-RS60-4 | Steel shelving unit, 14" D x 60" W x 62" H |

Aisle space calculated for this package is based on an 84" wide box.



BOX TRUCK STEP VAN & TRAILER

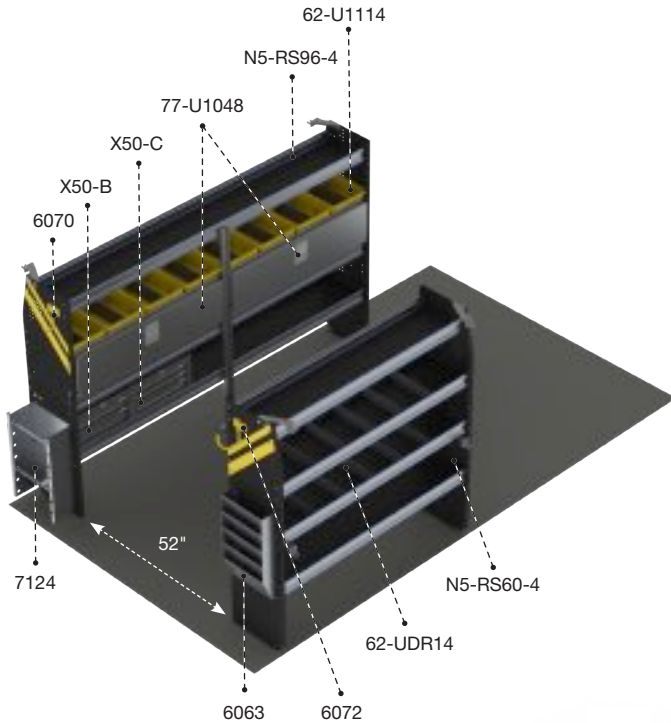

BTS-11
ELECTRICAL

| | | | | | |
|--|---------|--|-----------|--|-----------|
| | Steel | | Short 10+ | | High Roof |
| | 324 lbs | | 5.3 hrs | | Yes |

| Qty | Part | Description |
|-----|-----------|---------------------------------------------------------------|
| 1 | 6063 | Paper holder, extra deep, 5 slots |
| 1 | 6070 | 6" Hook, 3" opening, painted |
| 1 | 6072 | 8" Swivel hook, 4" opening, painted |
| 8 | 62-U1114 | 14" Deep plastic bin |
| 2 | 62-UDR14 | Set of 5 dividers for a 14" shelf |
| 1 | 7124 | Reel holder with two 5/8" diameter rods |
| 2 | 77-U1048 | Adjustable shelving door unit - 45" W - for 48" & 96" shelves |
| 1 | N5-RS60-4 | Steel shelving unit, 14" D x 60" W x 62" H |
| 1 | N5-RS96-4 | Steel shelving unit, 14" D x 96" W x 62" H |
| 1 | X50-B | Compact 2-drawer unit |
| 1 | X50-C | Compact 3-drawer unit |

Aisle space calculated for this package is based on an 84" wide box.

PACKAGES

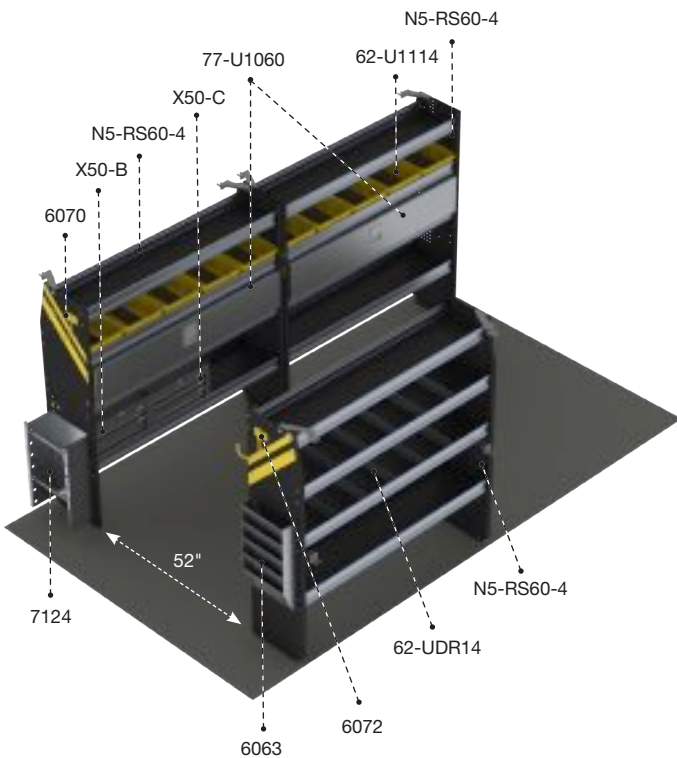

BTL-11
ELECTRICAL

| | | | | | |
|--|---------|--|----------|--|-----------|
| | Steel | | Long 14+ | | High Roof |
| | 386 lbs | | 6.3 hrs | | Yes |

| Qty | Part | Description |
|-----|-----------|---------------------------------------------------------|
| 1 | 6063 | Paper holder, extra deep, 5 slots |
| 1 | 6070 | 6" Hook, 3" opening, painted |
| 1 | 6072 | 8" Swivel hook, 4" opening, painted |
| 10 | 62-U1114 | 14" Deep plastic bin |
| 2 | 62-UDR14 | Set of 5 dividers for a 14" shelf |
| 1 | 7124 | Reel holder with two 5/8" diameter rods |
| 2 | 77-U1060 | Adjustable shelving door unit - 57" W - for 60" shelves |
| 3 | N5-RS60-4 | Steel shelving unit, 14" D x 60" W x 62" H |
| 1 | X50-B | Compact 2-drawer unit |
| 1 | X50-C | Compact 3-drawer unit |

Aisle space calculated for this package is based on an 84" wide box.

BOX TRUCK STEP VAN & TRAILER



PACKAGES

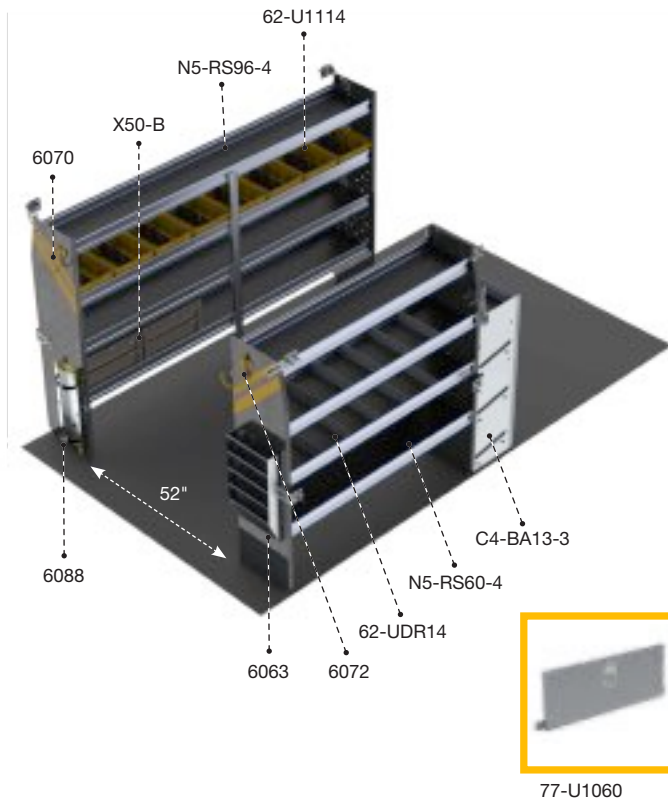

BTS-12 HVAC

| | | |
|---------|-----------|-----------|
| Steel | Short 10+ | High Roof |
| 334 lbs | 5.1 hrs | Yes |

| Qty | Part | Description |
|-----|------------------|-----------------------------------------------------------|
| 1 | C4-BA13-3 | 3 Tier refrigerant rack for large bottles |
| 1 | 6063 | Paper holder, extra deep, 5 slots |
| 1 | 6070 | 6" Hook, 3" opening, painted |
| 1 | 6072 | 8" Swivel hook, 4" opening, painted |
| 1 | 6088 | Large aluminum bottle holder, with two black nylon straps |
| 8 | 62-U1114 | 14" Deep plastic bin |
| 2 | 62-UDR14 | Set of 5 dividers for a 14" shelf |
| 1 | 77-U1060 | Adjustable shelving door unit - 57" W - for 60" shelves |
| 1 | N5-RS60-4 | Steel shelving unit, 14" D x 60" W x 62" H |
| 1 | N5-RS96-4 | Steel shelving unit, 14" D x 96" W x 62" H |
| 2 | X50-B | Compact 2-drawer unit |

Aisle space calculated for this package is based on an 84" wide box.

Packages BTS-12 and BTL-12 are designed for boxes with side access. For boxes with no side access, it is recommended to reposition the C4-BA13-3 bottle rack.

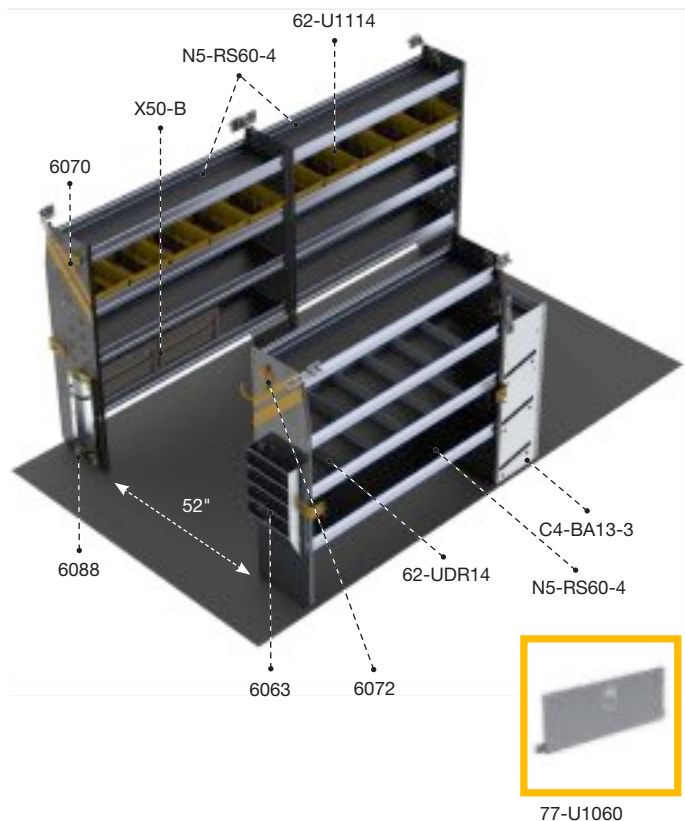

BTL-12 HVAC

| | | |
|---------|----------|-----------|
| Steel | Long 14+ | High Roof |
| 393 lbs | 6.1 hrs | Yes |

| Qty | Part | Description |
|-----|------------------|-----------------------------------------------------------|
| 1 | C4-BA13-3 | 3 Tier refrigerant rack for large bottles |
| 1 | 6063 | Paper holder, extra deep, 5 slots |
| 1 | 6070 | 6" Hook, 3" opening, painted |
| 1 | 6072 | 8" Swivel hook, 4" opening, painted |
| 1 | 6088 | Large aluminum bottle holder, with two black nylon straps |
| 10 | 62-U1114 | 14" Deep plastic bin |
| 2 | 62-UDR14 | Set of 5 dividers for a 14" shelf |
| 1 | 77-U1060 | Adjustable shelving door unit - 57" W - for 60" shelves |
| 3 | N5-RS60-4 | Steel shelving units, 14" D x 60" W x 62" H |
| 2 | X50-B | Compact 2-drawer unit |

Aisle space calculated for this package is based on an 84" wide box.



HVAC **BTL-12**

BOX TRUCK STEP VAN & TRAILER



LEGEND



Wheelbase



Roof Height



Weight



Estimated Install Time



Quickship

BOX TRUCK STEP VAN & TRAILER



PACKAGES

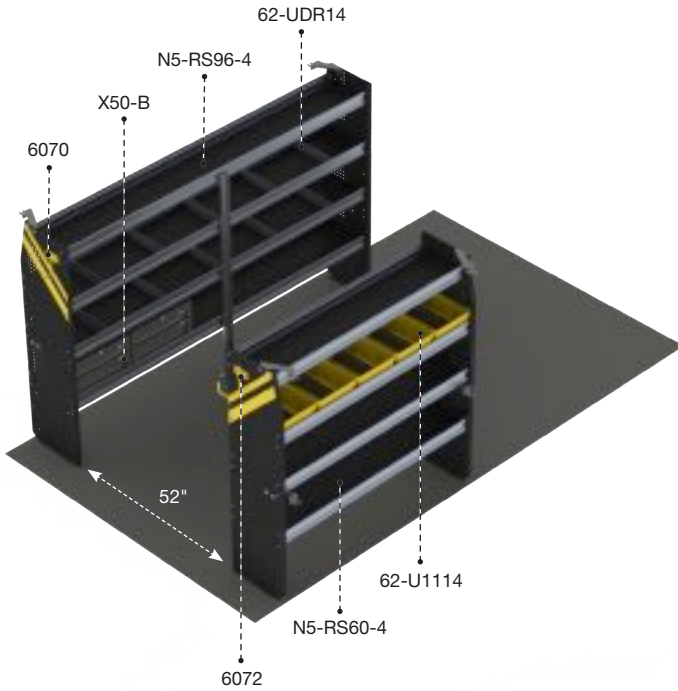

BTS-16 SERVICE

| | | |
|---------|-----------|-----------|
| Steel | Short 10+ | High Roof |
| 281 lbs | 3.6 hrs | Yes |

| Qty | Part | Description |
|-----|-----------|--------------------------------------------|
| 1 | 6070 | 6" Hook, 3" opening, painted |
| 1 | 6072 | 8" Swivel hook, 4" opening, painted |
| 5 | 62-U1114 | 14" Deep plastic bin |
| 2 | 62-UDR14 | Set of 5 dividers for a 14" shelf |
| 1 | N5-RS60-4 | Steel shelving unit, 14" D x 60" W x 62" H |
| 1 | N5-RS96-4 | Steel shelving unit, 14" D x 96" W x 62" H |
| 2 | X50-B | Compact 2-drawer unit |

Aisle space calculated for this package is based on an 84" wide box.

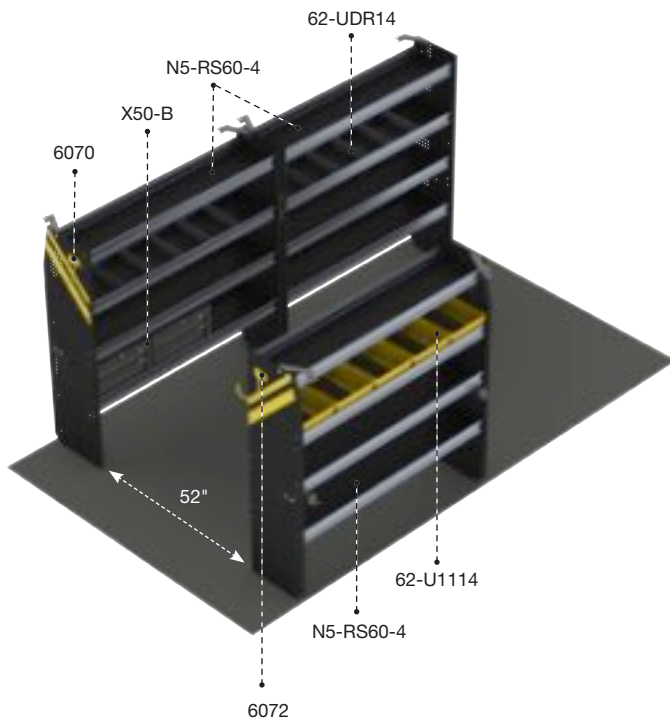

BTL-16 SERVICE

| | | |
|---------|----------|-----------|
| Steel | Long 14+ | High Roof |
| 336 lbs | 4.6 hrs | Yes |

| Qty | Part | Description |
|-----|-----------|---------------------------------------------|
| 1 | 6070 | 6" Hook, 3" opening, painted |
| 1 | 6072 | 8" Swivel hook, 4" opening, painted |
| 5 | 62-U1114 | 14" Deep plastic bin |
| 2 | 62-UDR14 | Set of 5 dividers for a 14" shelf |
| 3 | N5-RS60-4 | Steel shelving units, 14" D x 60" W x 62" H |
| 2 | X50-B | Compact 2-drawer unit |

Aisle space calculated for this package is based on an 84" wide box.



BOX TRUCK STEP VAN & TRAILER

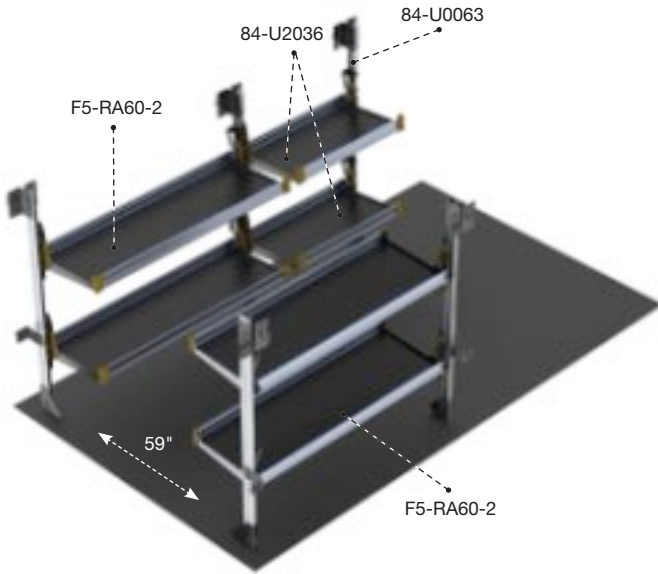

BTS-19
DELIVERY

| | | |
|----------|-----------|-----------|
| Aluminum | Short 10+ | High Roof |
| 212 lbs | 4.3 hrs | Yes |

| Qty | Part | Description |
|-----|-----------|-------------------------------------------------|
| 1 | 84-U0063 | Post assembly for fold-away shelving 63" |
| 2 | 84-U2036 | Fold-away shelf tray, 20" D x 36" W |
| 2 | F5-RA60-2 | Fold-away unit, 2 levels, 25" D x 60" W x 63" H |

Aisle space calculated for this package is based on an 84" wide box.

PACKAGES

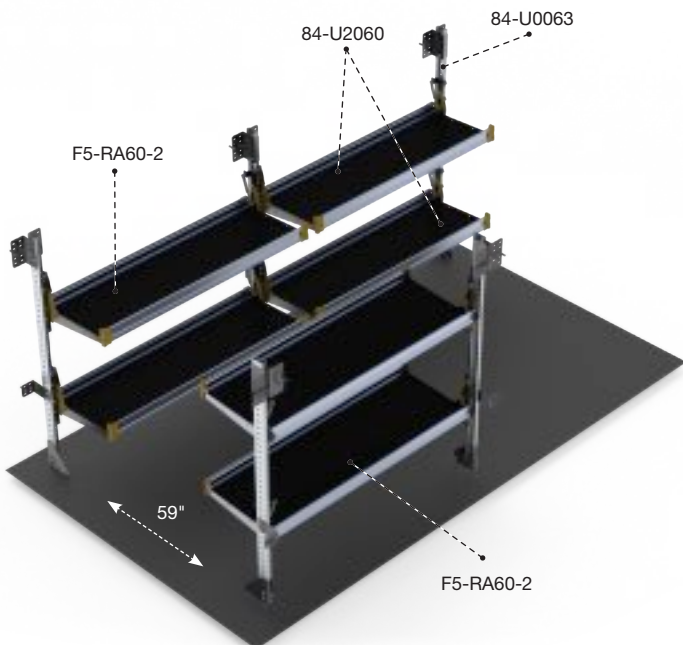

BTL-19
DELIVERY

| | | |
|----------|----------|-----------|
| Aluminum | Long 14+ | High Roof |
| 226 lbs | 4.3 hrs | Yes |

| Qty | Part | Description |
|-----|-----------|-------------------------------------------------|
| 1 | 84-U0063 | Post assembly for fold-away shelving 63" |
| 2 | 84-U2060 | Fold-away shelf tray, 60" W x 20" D |
| 2 | F5-RA60-2 | Fold-away unit, 2 levels, 25" D x 60" W x 63" H |

Aisle space calculated for this package is based on an 84" wide box.

BOX TRUCK STEP VAN & TRAILER



PACKAGES

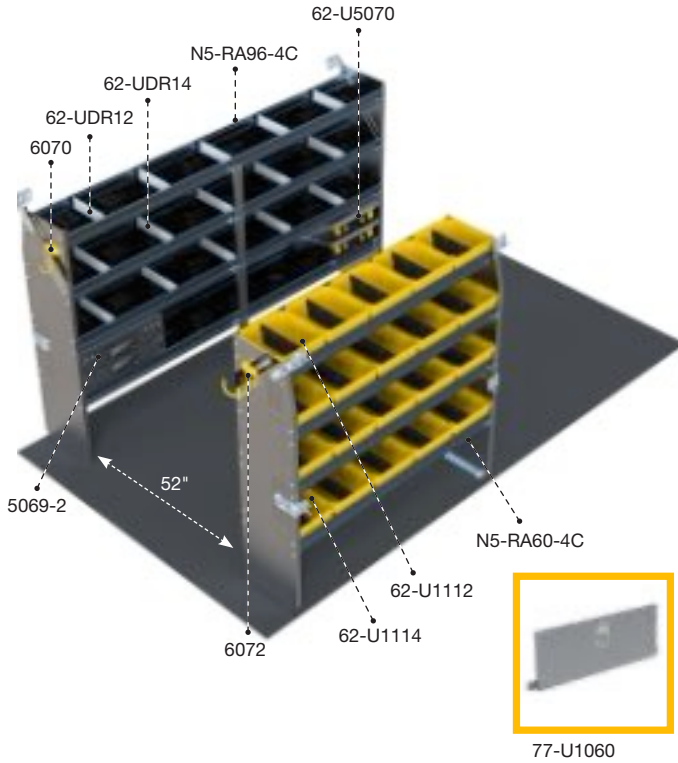

BTS-27 ALUMINUM

| | | |
|----------|-----------|-----------|
| Aluminum | Short 10+ | High Roof |
| 246 lbs | 4.6 hrs | Yes |

| Qty | Part | Description |
|-----|------------|------------------------------------------------------------|
| 1 | 5069-2 | 2 Drawer cabinet |
| 2 | 62-U5070 | Partskeeper carry case with holder |
| 1 | 6070 | 6" Hook, 3" opening, painted |
| 1 | 6072 | 8" Swivel hook, 4" opening, painted |
| 5 | 62-U1112 | 12" Deep plastic bin |
| 15 | 62-U1114 | 14" Deep plastic bin |
| 1 | 62-UDR12 | Set of 5 dividers for a 12" shelf |
| 2 | 62-UDR14 | Set of 5 dividers for a 14" shelf |
| 1 | 77-U1060 | Adjustable shelving door unit - 57" W - for 60" shelves |
| 1 | N5-RA60-4C | Composite Aluminum shelving unit, 60", 14"D x 60" W x 62"H |
| 1 | N5-RA96-4C | Composite Aluminum shelving unit, 96", 14"D x 96" W x 62"H |

Aisle space calculated for this package is based on an 84" wide box.

BTL-27 ALUMINUM

| | | |
|----------|----------|-----------|
| Aluminum | Long 14+ | High Roof |
| 281 lbs | 6.8 hrs | Yes |

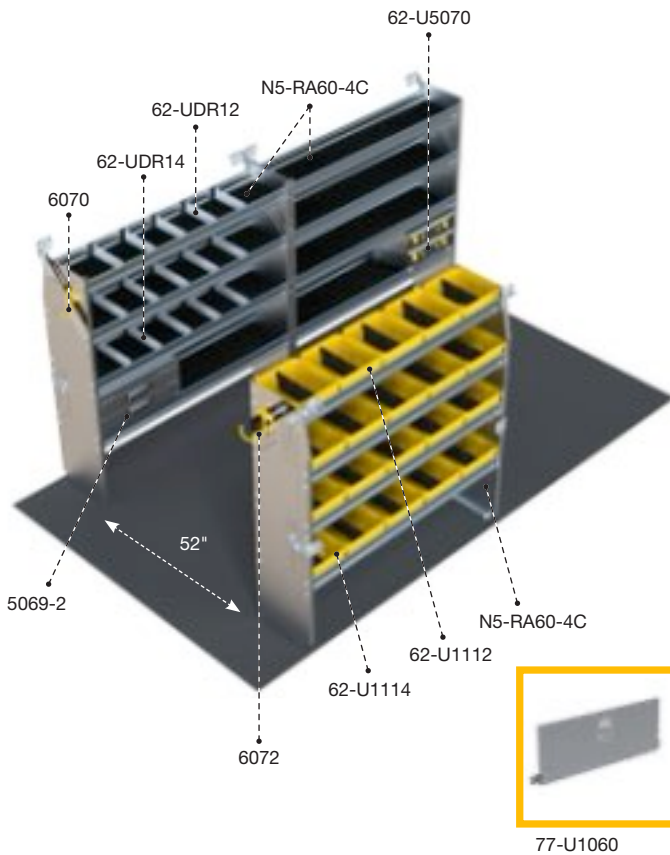

| Qty | Part | Description |
|-----|------------|------------------------------------------------------------|
| 1 | 5069-2 | 2 Drawer cabinet |
| 2 | 62-U5070 | Partskeeper carry case with holder |
| 1 | 6070 | 6" Hook, 3" opening, painted |
| 1 | 6072 | 8" Swivel hook, 4" opening, painted |
| 5 | 62-U1112 | 12" Deep plastic bin |
| 15 | 62-U1114 | 14" Deep plastic bin |
| 1 | 62-UDR12 | Set of 5 dividers for a 12" shelf |
| 2 | 62-UDR14 | Set of 5 dividers for a 14" shelf |
| 1 | 77-U1060 | Adjustable shelving door unit - 57" W - for 60" shelves |
| 3 | N5-RA60-4C | Composite Aluminum shelving unit, 60", 14"D x 60" W x 62"H |

Aisle space calculated for this package is based on an 84" wide box.



CHEVROLET EXPRESS

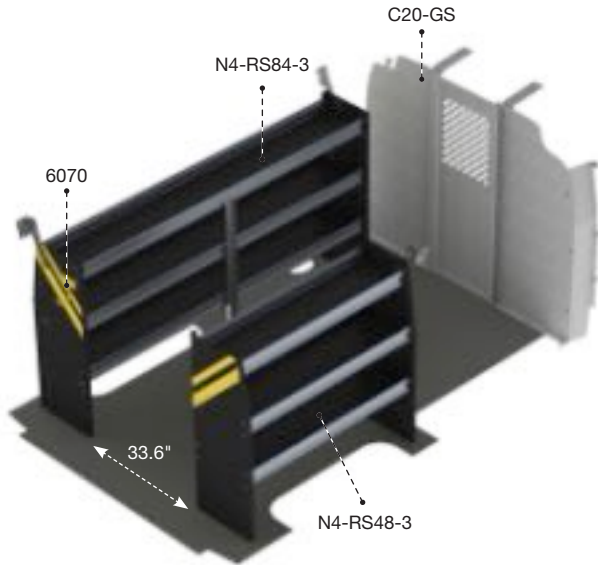

GSR-10 CONTRACTOR

| | | |
|---------|---------|----------|
| Steel | 135" | Standard |
| 203 lbs | 3.8 hrs | Yes |

| Qty | Part | Description |
|-----|-----------|------------------------------------------------------------|
| 1 | 6070 | 6" Hook, 3" opening, painted |
| 1 | C20-GS | Straight steel partition with perforated window, no access |
| 1 | N4-RS48-3 | Steel shelving unit, 14" D x 48" W x 44.5" H |
| 1 | N4-RS84-3 | Steel shelving unit, 14" D x 84" W x 44.5" H |

PACKAGES

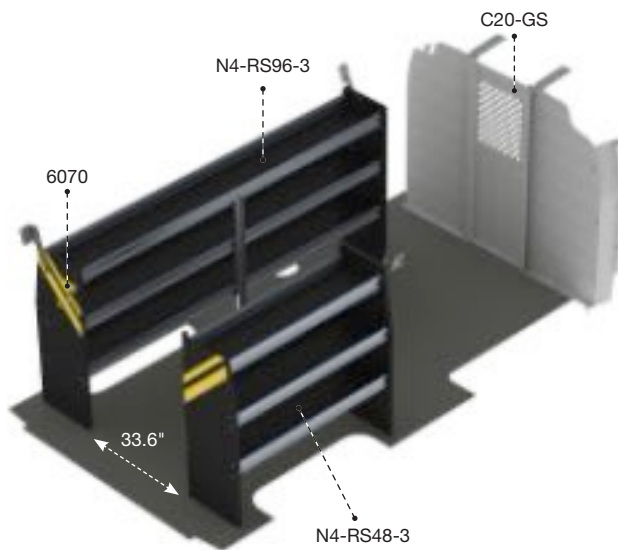

GSL-10 CONTRACTOR

| | | |
|---------|---------|----------|
| Steel | 155" | Standard |
| 211 lbs | 3.8 hrs | Yes |

| Qty | Part | Description |
|-----|-----------|------------------------------------------------------------|
| 1 | 6070 | 6" Hook, 3" opening, painted |
| 1 | C20-GS | Straight steel partition with perforated window, no access |
| 1 | N4-RS48-3 | Steel shelving unit, 14" D x 48" W x 44.5" H |
| 1 | N4-RS96-3 | Steel shelving unit, 14" D x 96" W x 44.5" H |

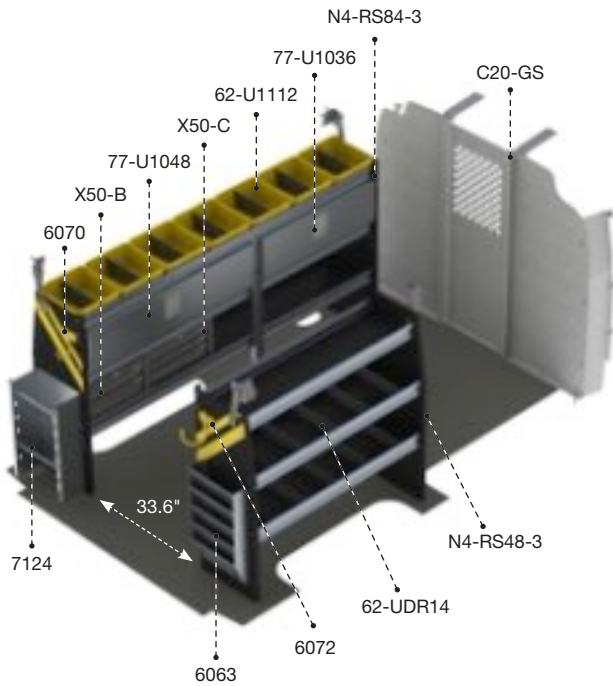

GSR-11 ELECTRICAL

| | | |
|---------|---------|----------|
| Steel | 135" | Standard |
| 311 lbs | 6.3 hrs | Yes |

| Qty | Part | Description |
|-----|-----------|---------------------------------------------------------------|
| 1 | 6063 | Paper holder, extra deep, 5 slots |
| 1 | 6070 | 6" Hook, 3" opening, painted |
| 1 | 6072 | 8" Swivel hook, 4" opening, painted |
| 1 | 7124 | Reel holder with two 5/8" diameter rods |
| 7 | 62-U1112 | 12" deep plastic bin |
| 2 | 62-UDR14 | Set of 5 dividers for a 14" Shelf |
| 1 | 77-U1036 | Adjustable shelving door unit - 33" W - for 36" & 72" shelves |
| 1 | 77-U1048 | Adjustable shelving door unit - 45" W - for 48" & 96" shelves |
| 1 | C20-GS | Straight steel partition with perforated window, no access |
| 1 | N4-RS48-3 | Steel shelving unit, 14" D x 48" W x 44.5" H |
| 1 | N4-RS84-3 | Steel shelving unit, 14" D x 84" W x 44.5" H |
| 1 | X50-B | Compact 2-drawer unit |
| 1 | X50-C | Compact 3-drawer unit |

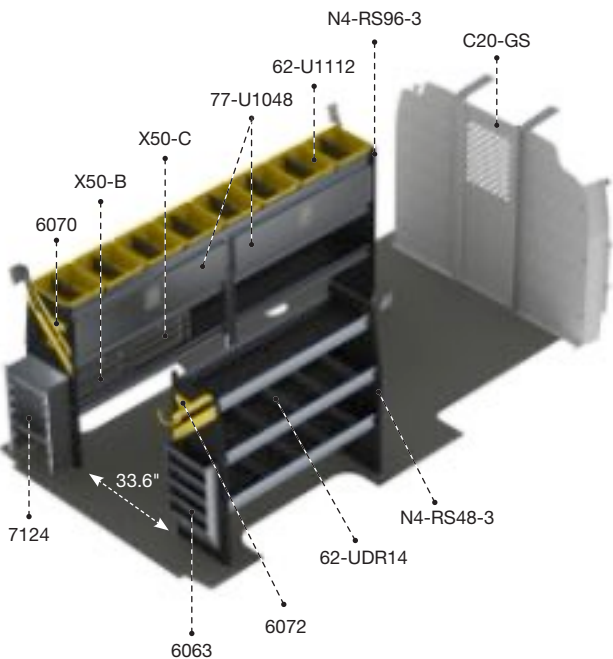

GSL-11 ELECTRICAL

| | | |
|---------|---------|----------|
| Steel | 155" | Standard |
| 322 lbs | 6.3 hrs | Yes |

| Qty | Part | Description |
|-----|-----------|---------------------------------------------------------------|
| 1 | 6063 | Paper holder, extra deep, 5 slots |
| 1 | 6070 | 6" Hook, 3" opening, painted |
| 1 | 6072 | 8" Swivel hook, 4" opening, painted |
| 1 | 7124 | Reel holder with two 5/8" diameter rods |
| 8 | 62-U1112 | 12" deep plastic bin |
| 2 | 62-UDR14 | Set of 5 dividers for a 14" Shelf |
| 2 | 77-U1048 | Adjustable shelving door unit - 45" W - for 48" & 96" shelves |
| 1 | C20-GS | Straight steel partition with perforated window, no access |
| 1 | N4-RS48-3 | Steel shelving unit, 14" D x 48" W x 44.5" H |
| 1 | N4-RS96-3 | Steel shelving unit, 14" D x 96" W x 44.5" H |
| 1 | X50-B | Compact 2-drawer unit |
| 1 | X50-C | Compact 3-drawer unit |



ELECTRICAL **GSR-11**

CHEVROLET **EXPRESS**



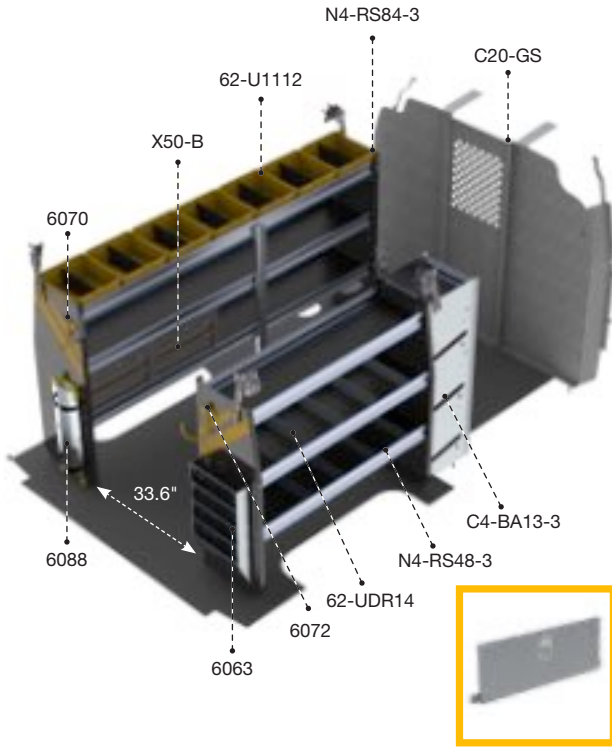

77-U1048

GSR-12 HVAC

| | | | | | |
|--|---------|--|---------|--|----------|
| | Steel | | 135" | | Standard |
| | 320 lbs | | 6.1 hrs | | Yes |

| Qty | Part | Description |
|-----|------------------|---------------------------------------------------------------|
| 1 | C4-BA13-3 | 3 Tier refrigerant rack for large bottles |
| 1 | 6063 | Paper holder, extra deep, 5 slots |
| 1 | 6070 | 6" Hook, 3" opening, painted |
| 1 | 6072 | 8" Swivel hook, 4" opening, painted |
| 1 | 6088 | Large aluminum bottle holder, with two black nylon straps |
| 7 | 62-U1112 | 12" deep plastic bin |
| 2 | 62-UDR14 | Set of 5 dividers for a 14" Shelf |
| 1 | 77-U1048 | Adjustable shelving door unit - 45" W - for 48" & 96" shelves |
| 1 | C20-GS | Straight steel partition with perforated window, no access |
| 1 | N4-RS48-3 | Steel shelving unit, 14" D x 48" W x 44.5" H |
| 1 | N4-RS84-3 | Steel shelving unit, 14" D x 84" W x 44.5" H |
| 2 | X50-B | Compact 2-drawer unit |

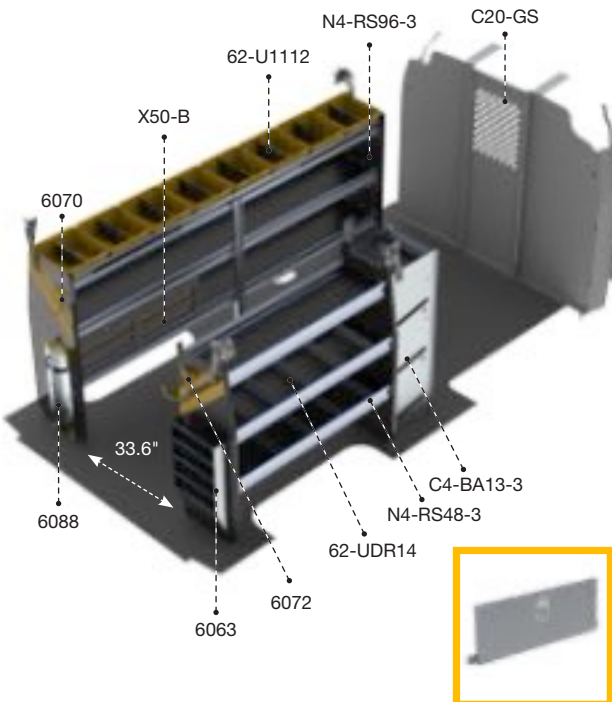

77-U1048

GSL-12 HVAC

| | | | | | |
|--|---------|--|---------|--|----------|
| | Steel | | 155" | | Standard |
| | 330 lbs | | 6.1 hrs | | Yes |

| Qty | Part | Description |
|-----|------------------|---------------------------------------------------------------|
| 1 | C4-BA13-3 | 3 Tier refrigerant rack for large bottles |
| 1 | 6063 | Paper holder, extra deep, 5 slots |
| 1 | 6070 | 6" Hook, 3" opening, painted |
| 1 | 6072 | 8" Swivel hook, 4" opening, painted |
| 1 | 6088 | Large aluminum bottle holder, with two black nylon straps |
| 8 | 62-U1112 | 12" deep plastic bin |
| 2 | 62-UDR14 | Set of 5 dividers for a 14" Shelf |
| 1 | 77-U1048 | Adjustable shelving door unit - 45" W - for 48" & 96" shelves |
| 1 | C20-GS | Straight steel partition with perforated window, no access |
| 1 | N4-RS48-3 | Steel shelving unit, 14" D x 48" W x 44.5" H |
| 1 | N4-RS96-3 | Steel shelving unit, 14" D x 96" W x 44.5" H |
| 2 | X50-B | Compact 2-drawer unit |



CHEVROLET EXPRESS

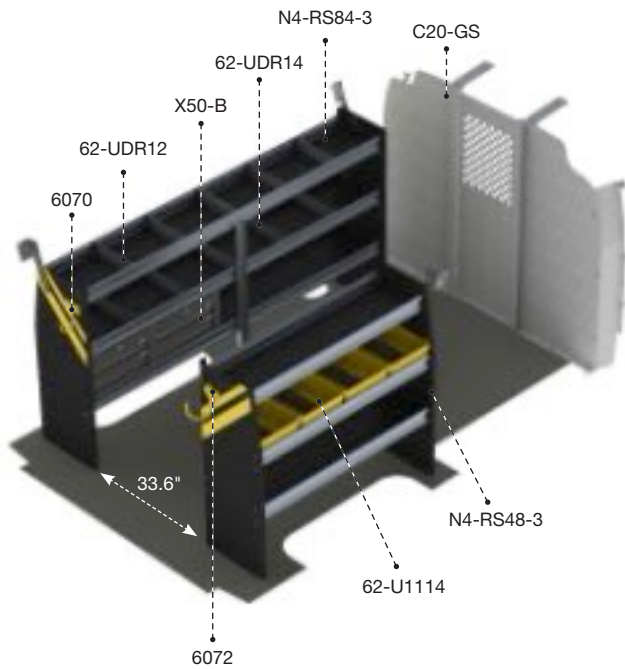

GSR-16 SERVICE

| | | |
|---------|---------|----------|
| Steel | 135" | Standard |
| 270 lbs | 4.6 hrs | Yes |

| Qty | Part | Description |
|-----|-----------|------------------------------------------------------------|
| 1 | 6070 | 6" Hook, 3" opening, painted |
| 1 | 6072 | 8" Swivel hook, 4" opening, painted |
| 4 | 62-U1114 | 14" deep plastic bin |
| 1 | 62-UDR12 | Set of 5 dividers for a 12" Shelf |
| 1 | 62-UDR14 | Set of 5 dividers for a 14" Shelf |
| 1 | C20-GS | Straight steel partition with perforated window, no access |
| 1 | N4-RS48-3 | Steel shelving unit, 14" D x 48" W x 44.5" H |
| 1 | N4-RS84-3 | Steel shelving unit, 14" D x 84" W x 44.5" H |
| 2 | X50-B | Compact 2-drawer unit |

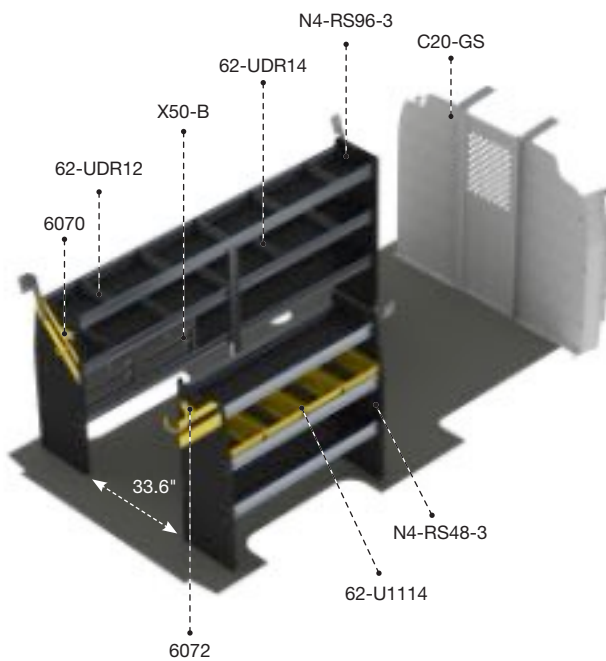

GSL-16 SERVICE

| | | |
|---------|---------|----------|
| Steel | 155" | Standard |
| 278 lbs | 4.6 hrs | Yes |

| Qty | Part | Description |
|-----|-----------|------------------------------------------------------------|
| 1 | 6070 | 6" Hook, 3" opening, painted |
| 1 | 6072 | 8" Swivel hook, 4" opening, painted |
| 4 | 62-U1114 | 14" deep plastic bin |
| 1 | 62-UDR12 | Set of 5 dividers for a 12" Shelf |
| 1 | 62-UDR14 | Set of 5 dividers for a 14" Shelf |
| 1 | C20-GS | Straight steel partition with perforated window, no access |
| 1 | N4-RS48-3 | Steel shelving unit, 14" D x 48" W x 44.5" H |
| 1 | N4-RS96-3 | Steel shelving unit, 14" D x 96" W x 44.5" H |
| 2 | X50-B | Compact 2-drawer unit |

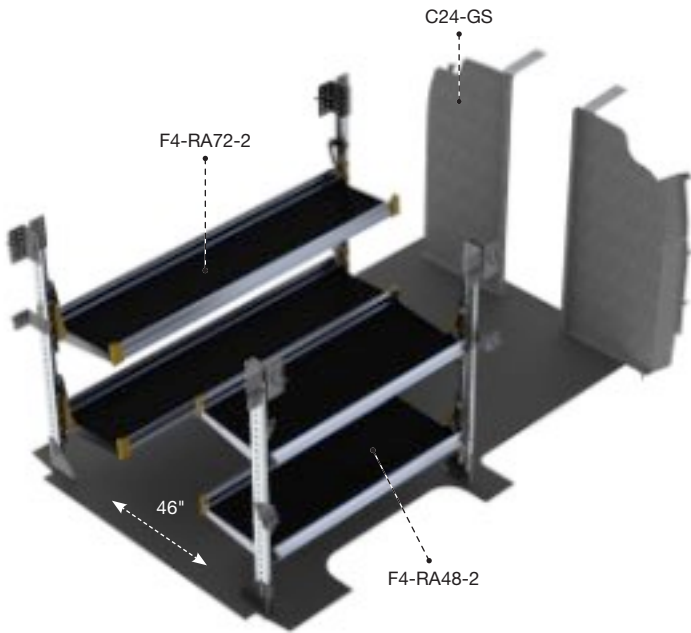

GSR-19 DELIVERY

| | | |
|----------|---------|----------|
| Aluminum | 135" | Standard |
| 195 lbs | 4.2 hrs | Yes |

| Qty | Part | Description |
|-----|------------------|-------------------------------------------------|
| 1 | C24-GS | Straight walk through steel partition |
| 1 | F4-RA72-2 | Fold-away unit, 2 levels, 22" D x 72" W x 47" H |
| 1 | F4-RA48-2 | Fold-away unit, 2 levels, 22" D x 48" W x 47" H |

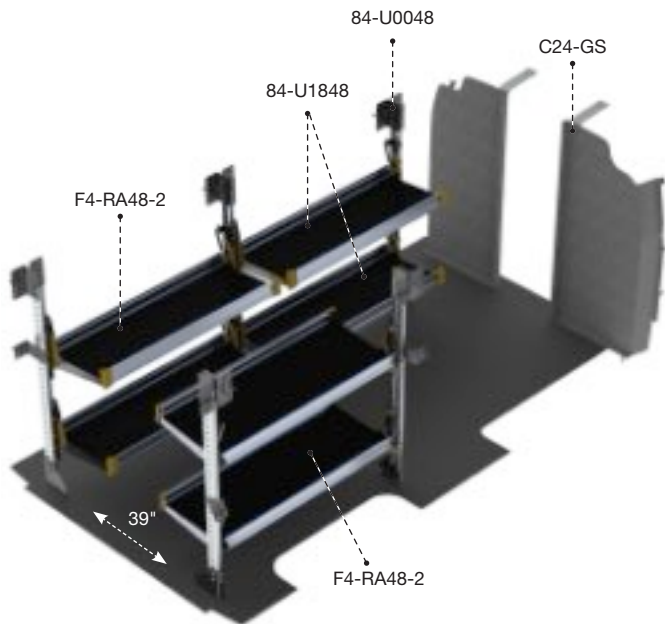

GSL-19 DELIVERY

| | | |
|----------|---------|----------|
| Aluminum | 155" | Standard |
| 239 lbs | 5.3 hrs | Yes |

| Qty | Part | Description |
|-----|------------------|-------------------------------------------------|
| 1 | 84-U0048 | Post assembly for fold-away shelving, 48" |
| 2 | 84-U1848 | Fold-away shelf tray, 18" D x 48" W |
| 1 | C24-GS | Straight walk through steel partition |
| 2 | F4-RA48-2 | Fold-away unit, 2 levels, 22" D x 48" W x 47" H |



CHEVROLET EXPRESS

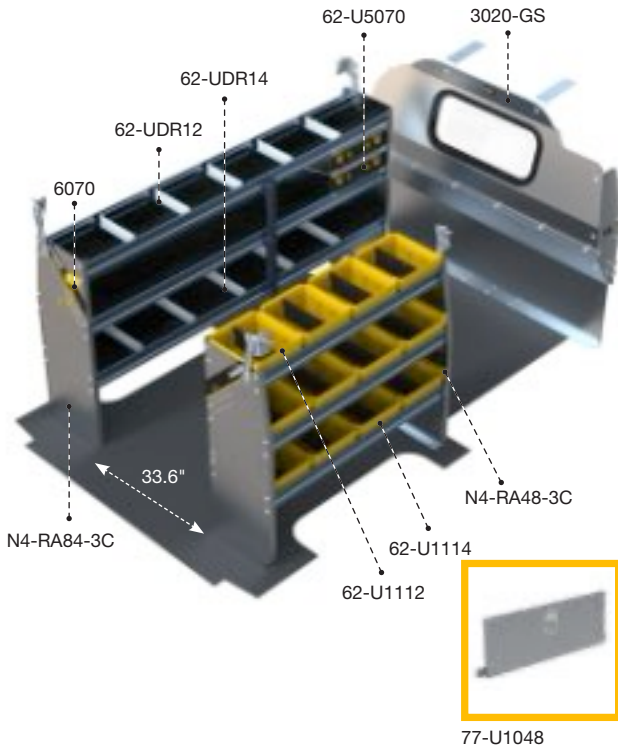

GSR-27
ALUMINUM

| | | |
|----------|---------|----------|
| Aluminum | 135" | Standard |
| 205 lbs | 4.4 hrs | Yes |

| Qty | Part | Description |
|-----|-------------------|---------------------------------------------------------------|
| 1 | 3020-GS | Countoured safety partition with glass window |
| 2 | 62-U5070 | Partskeeper carry case with holder |
| 1 | 6070 | 6" Hook, 3" opening, painted |
| 4 | 62-U1112 | 12" deep plastic bin |
| 8 | 62-U1114 | 14" deep plastic bin |
| 1 | 62-UDR12 | Set of 5 dividers for a 12" Shelf |
| 1 | 62-UDR14 | Set of 5 dividers for a 14" Shelf |
| 1 | 77-U1048 | Adjustable shelving door unit - 45" W - for 48" & 96" shelves |
| 1 | N4-RA48-3C | Composite Aluminum shelving unit, 14" D x 48" W x 44.5" H |
| 1 | N4-RA84-3C | Composite Aluminum shelving unit, 14" D x 84" W x 44.5" H |

PACKAGES

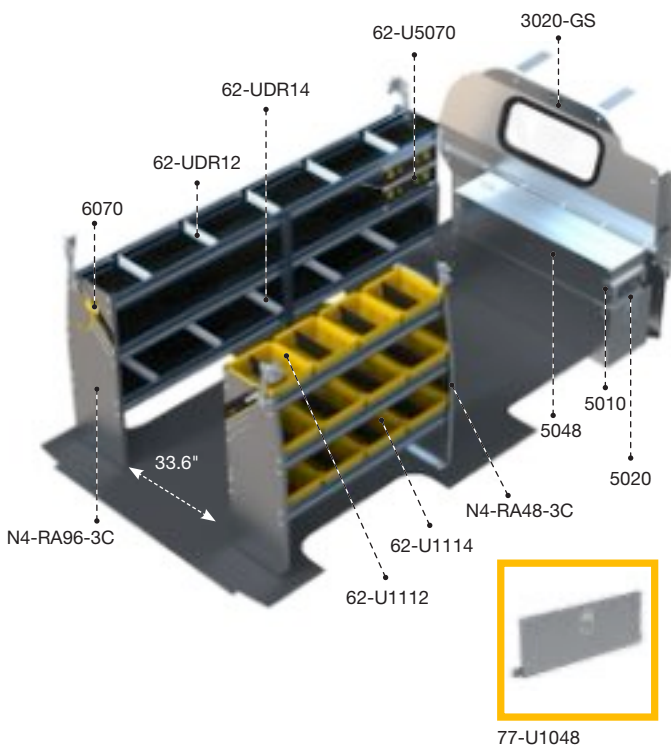

GSL-27
ALUMINUM



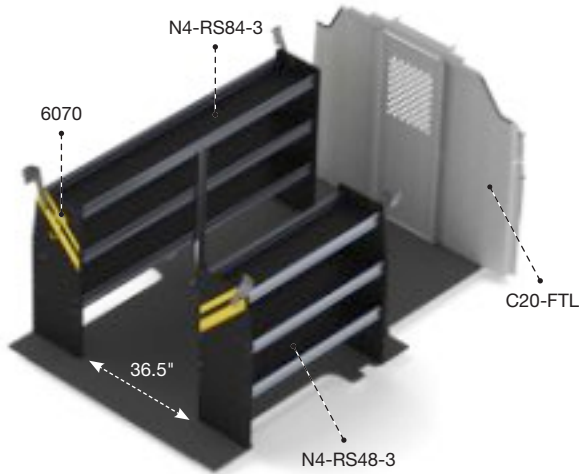

| | | |
|----------|---------|----------|
| Aluminum | 155" | Standard |
| 311 lbs | 6.1 hrs | Yes |

| Qty | Part | Description |
|-----|-------------------|---------------------------------------------------------------|
| 1 | 3020-GS | Countoured safety partition with glass window |
| 1 | 5010 | Partslider drawer 48" D |
| 1 | 5020 | Tool Drawer 48" D x 14" W x 16" H |
| 1 | 5048 | Top edge |
| 2 | 62-U5070 | Partskeeper carry case with holder |
| 1 | 6070 | 6" Hook, 3" opening, painted |
| 4 | 62-U1112 | 12" deep plastic bin |
| 8 | 62-U1114 | 14" deep plastic bin |
| 1 | 62-UDR12 | Set of 5 dividers for a 12" Shelf |
| 1 | 62-UDR14 | Set of 5 dividers for a 14" Shelf |
| 1 | 77-U1048 | Adjustable shelving door unit - 45" W - for 48" & 96" shelves |
| 1 | N4-RA48-3C | Composite Aluminum shelving unit, 14" D x 48" W x 44.5" H |
| 1 | N4-RA96-3C | Composite Aluminum shelving unit, 14" D x 96" W x 44.5" H |

FORD TRANSIT







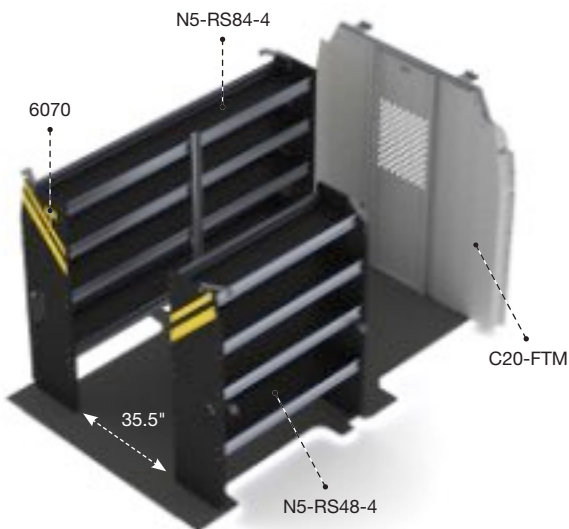

FTL-10 CONTRACTOR

| | | |
|-------------------------------------------------------------------------------------------|------------------------------------------------------------------------------------------------|----------------------------------------------------------------------------------------------|
|  Steel |  130", 148" |  Low Roof |
|  206 lbs |  3.3 hrs |  Yes |

| Qty | Part # | Description |
|-----|-----------|------------------------------------------------------------|
| 1 | 6070 | 6" Hook, 3" opening, painted |
| 1 | C20-FTL | Straight steel partition with perforated window, no access |
| 1 | N4-RS48-3 | Steel shelving unit, 14" D x 48" W x 44.5" H |
| 1 | N4-RS84-3 | Steel shelving unit, 14" D x 84" W x 44.5" H |



FTR-10 CONTRACTOR

| | | |
|---------------------------------------------------------------------------------------------|-----------------------------------------------------------------------------------------------|---------------------------------------------------------------------------------------------------|
|  Steel |  130" |  Medium Roof |
|  268 lbs |  3.8 hrs |  Yes |

| Qty | Part # | Description |
|-----|-----------|------------------------------------------------------------|
| 1 | 6070 | 6" Hook, 3" opening, painted |
| 1 | C20-FTM | Straight steel partition with perforated window, no access |
| 1 | N5-RS48-4 | Steel shelving unit, 14" D x 48" W x 62" H |
| 1 | N5-RS84-4 | Steel shelving unit, 14" D x 84" W x 62" H |

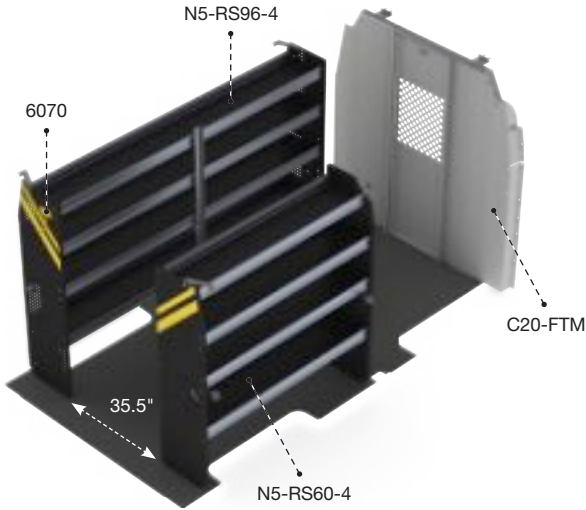

FTM-10 CONTRACTOR

| | | |
|---------|---------|-------------|
| Steel | 148" | Medium Roof |
| 288 lbs | 3.8 hrs | Yes |

| Qty | Part # | Description |
|-----|-----------|------------------------------------------------------------|
| 1 | 6070 | 6" Hook, 3" opening, painted |
| 1 | C20-FTM | Straight steel partition with perforated window, no access |
| 1 | N5-RS60-4 | Steel shelving unit, 14" D x 60" W x 62" H |
| 1 | N5-RS96-4 | Steel shelving unit, 14" D x 96" W x 62" H |

PACKAGES

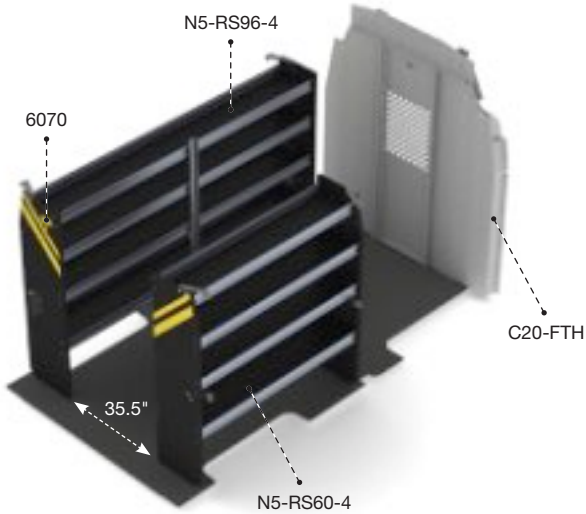

FTH-10 CONTRACTOR

| | | |
|---------|-----------------|-----------|
| Steel | 148", 148" Ext. | High Roof |
| 303 lbs | 3.8 hrs | Yes |

| Qty | Part # | Description |
|-----|-----------|------------------------------------------------------------|
| 1 | 6070 | 6" Hook, 3" opening, painted |
| 1 | C20-FTH | Straight steel partition with perforated window, no access |
| 1 | N5-RS60-4 | Steel shelving unit, 14" D x 60" W x 62" H |
| 1 | N5-RS96-4 | Steel shelving unit, 14" D x 96" W x 62" H |

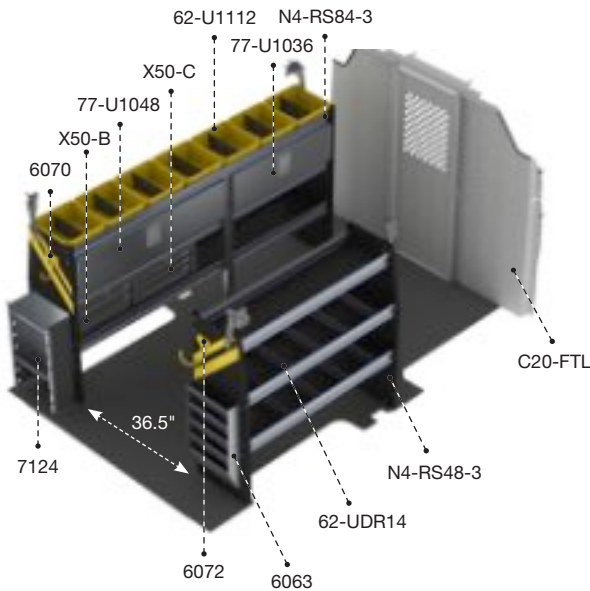

FTL-11 ELECTRICAL

| | | | | | |
|--|---------|--|------------|--|----------|
| | Steel | | 130", 148" | | Low Roof |
| | 314 lbs | | 5.8 hrs | | Yes |

| Qty | Part # | Description |
|-----|-----------|-----------------------------------------------------------------|
| 1 | 6063 | Paper holder, extra deep, 5 slots |
| 1 | 6070 | 6" Hook, 3" opening, painted |
| 1 | 6072 | 8" Swivel hook, 4" opening, painted |
| 7 | 62-U1112 | 12" Deep plastic bin |
| 2 | 62-UDR14 | Set of 5 dividers for a 14" shelf |
| 1 | 7124 | Reel holder with two 5/8" diameter rods |
| 1 | 77-U1036 | Adjustable shelving door unit - 33" W - for 36" and 72" shelves |
| 1 | 77-U1048 | Adjustable shelving door unit - 45" W - for 48" and 96" shelves |
| 1 | C20-FTL | Straight steel partition with perforated window, no access |
| 1 | N4-RS48-3 | Steel shelving unit, 14"D x 48" W x 44.5"H |
| 1 | N4-RS84-3 | Steel shelving unit, 14"D x 84" W x 44.5"H |
| 1 | X50-B | Compact 2-drawer unit |
| 1 | X50-C | Compact 3-drawer unit |

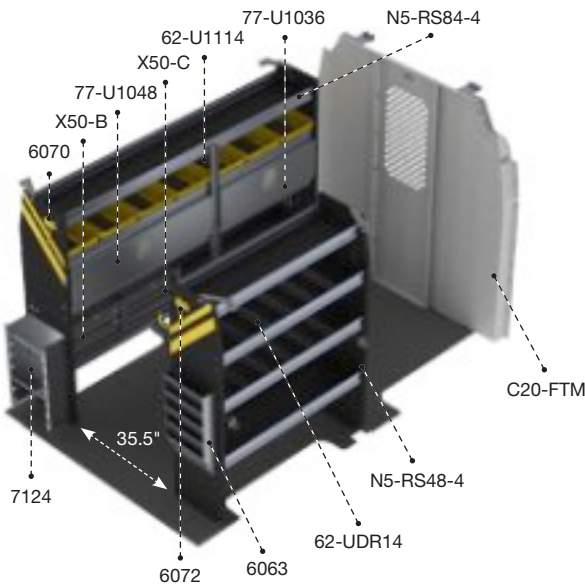

FTR-11 ELECTRICAL

| | | | | | |
|--|---------|--|---------|--|-------------|
| | Steel | | 130" | | Medium Roof |
| | 377 lbs | | 6.3 hrs | | Yes |

| Qty | Part # | Description |
|-----|-----------|-----------------------------------------------------------------|
| 1 | 6063 | Paper holder, extra deep, 5 slots |
| 1 | 6070 | 6" Hook, 3" opening, painted |
| 1 | 6072 | 8" Swivel hook, 4" opening, painted |
| 7 | 62-U1114 | 14" Deep plastic bin |
| 2 | 62-UDR14 | Set of 5 dividers for a 14" shelf |
| 1 | 7124 | Reel holder with two 5/8" diameter rods |
| 1 | 77-U1036 | Adjustable shelving door unit - 33" W - for 36" and 72" shelves |
| 1 | 77-U1048 | Adjustable shelving door unit - 45" W - for 48" and 96" shelves |
| 1 | C20-FTM | Straight steel partition with perforated window, no access |
| 1 | N5-RS48-4 | Steel shelving unit, 14"D x 48" W x 62"H |
| 1 | N5-RS84-4 | Steel shelving unit, 14"D x 84" W x 62"H |
| 1 | X50-B | Compact 2-drawer unit |
| 1 | X50-C | Compact 3-drawer unit |





ELECTRICAL **FTM-11**

FORD TRANSIT

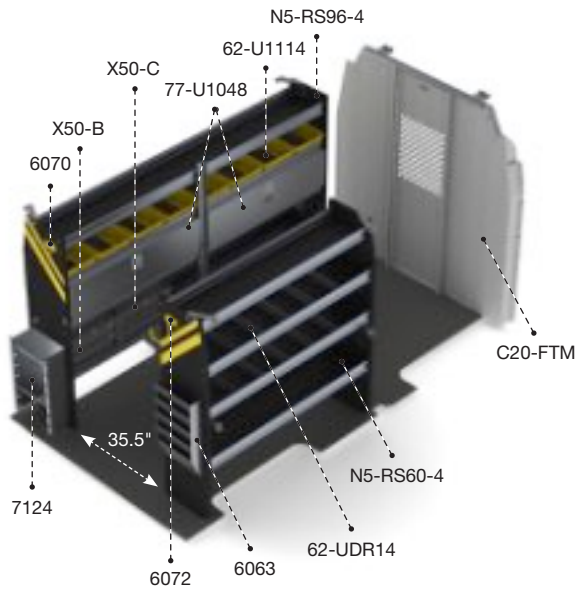



FTM-11 ELECTRICAL

| | | |
|-------------------------------------------------------------------------------------------|---------------------------------------------------------------------------------------------|-------------------------------------------------------------------------------------------------|
|  Steel |  148" |  Medium Roof |
|  401 lbs |  6.3 hrs |  Yes |

| Qty | Part # | Description |
|-----|-----------|-----------------------------------------------------------------|
| 1 | 6063 | Paper holder, extra deep, 5 slots |
| 1 | 6070 | 6" Hook, 3" opening, painted |
| 1 | 6072 | 8" Swivel hook, 4" opening, painted |
| 8 | 62-U1114 | 14" Deep plastic bin |
| 2 | 62-UDR14 | Set of 5 dividers for a 14" shelf |
| 1 | 7124 | Reel holder with two 5/8" diameter rods |
| 2 | 77-U1048 | Adjustable shelving door unit - 45" W - for 48" and 96" shelves |
| 1 | C20-FTM | Straight steel partition with perforated window, no access |
| 1 | N5-RS60-4 | Steel shelving unit, 14"D x 60" W x 62" H |
| 1 | N5-RS96-4 | Steel shelving unit, 14"D x 96" W x 62" H |
| 1 | X50-B | Compact 2-drawer unit |
| 1 | X50-C | Compact 3-drawer unit |

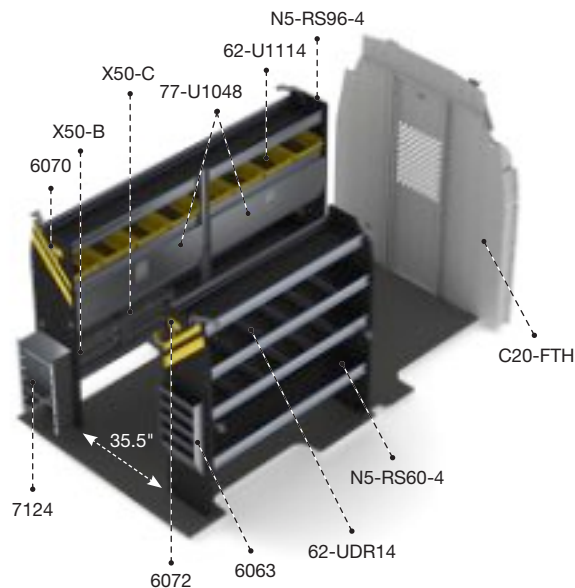

FTH-11 ELECTRICAL

| | | |
|---------------------------------------------------------------------------------------------|-------------------------------------------------------------------------------------------------------|-------------------------------------------------------------------------------------------------|
|  Steel |  148", 148" Ext. |  High Roof |
|  416 lbs |  6.3 hrs |  Yes |

| Qty | Part # | Description |
|-----|-----------|-----------------------------------------------------------------|
| 1 | 6063 | Paper holder, extra deep, 5 slots |
| 1 | 6070 | 6" Hook, 3" opening, painted |
| 1 | 6072 | 8" Swivel hook, 4" opening, painted |
| 8 | 62-U1114 | 14" Deep plastic bin |
| 2 | 62-UDR14 | Set of 5 dividers for a 14" shelf |
| 1 | 7124 | Reel holder with two 5/8" diameter rods |
| 2 | 77-U1048 | Adjustable shelving door unit - 45" W - for 48" and 96" shelves |
| 1 | C20-FTH | Straight steel partition with perforated window, no access |
| 1 | N5-RS60-4 | Steel shelving unit, 14"D x 60" W x 62" H |
| 1 | N5-RS96-4 | Steel shelving unit, 14"D x 96" W x 62" H |
| 1 | X50-B | Compact 2-drawer unit |
| 1 | X50-C | Compact 3-drawer unit |



FORD TRANSIT

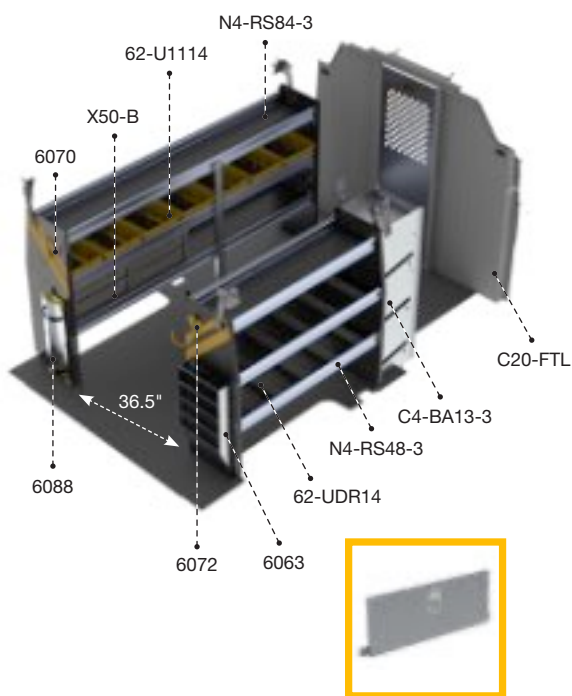

77-U1048

FTL-12 HVAC

| | | |
|---------|------------|----------|
| Steel | 130", 148" | Low Roof |
| 325 lbs | 5.6 hrs | Yes |

| Qty | Part # | Description |
|-----|------------------|---------------------------------------------------------------|
| 1 | C4-BA13-3 | 3 Tier refrigerant rack for large bottles |
| 1 | 6063 | Paper holder, extra deep, 5 slots |
| 1 | 6070 | 6" Hook, 3" opening, painted |
| 1 | 6072 | 8" Swivel hook, 4" opening, painted |
| 1 | 6088 | Large aluminum bottle holder, with two black nylon straps |
| 7 | 62-U1114 | 14" Deep plastic bin |
| 2 | 62-UDR14 | Set of 5 dividers for a 14" shelf |
| 1 | 77-U1048 | Adjustable shelving door unit - 45" W - for 48" & 96" shelves |
| 1 | C20-FTL | Straight steel partition with perforated window, no access |
| 1 | N4-RS48-3 | Steel shelving unit, 14" D x 48" W x 44.5" H |
| 1 | N4-RS84-3 | Steel shelving unit, 14" D x 84" W x 44.5" H |
| 2 | X50-B | Compact 2-drawer unit |

PACKAGES

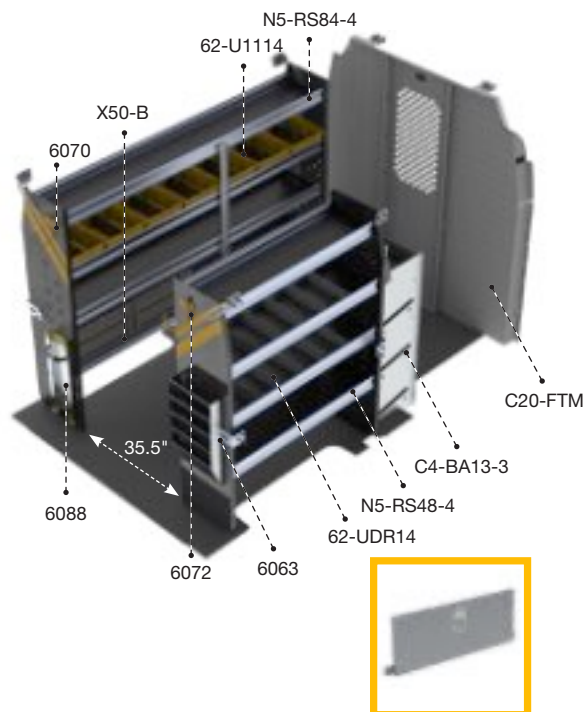

77-U1048

FTR-12 HVAC

| | | |
|---------|---------|-------------|
| Steel | 130" | Medium Roof |
| 387 lbs | 6.1 hrs | Yes |

| Qty | Part # | Description |
|-----|------------------|---------------------------------------------------------------|
| 1 | C4-BA13-3 | 3 Tier refrigerant rack for large bottles |
| 1 | 6063 | Paper holder, extra deep, 5 slots |
| 1 | 6070 | 6" Hook, 3" opening, painted |
| 1 | 6072 | 8" Swivel hook, 4" opening, painted |
| 1 | 6088 | Large aluminum bottle holder, with two black nylon straps |
| 7 | 62-U1114 | 14" Deep plastic bin |
| 2 | 62-UDR14 | Set of 5 dividers for a 14" shelf |
| 1 | 77-U1048 | Adjustable shelving door unit - 45" W - for 48" & 96" shelves |
| 1 | C20-FTM | Straight steel partition with perforated window, no access |
| 1 | N5-RS48-4 | Steel shelving unit, 14" D x 48" W x 62" H |
| 1 | N5-RS84-4 | Steel shelving unit, 14" D x 84" W x 62" H |
| 2 | X50-B | Compact 2-drawer unit |

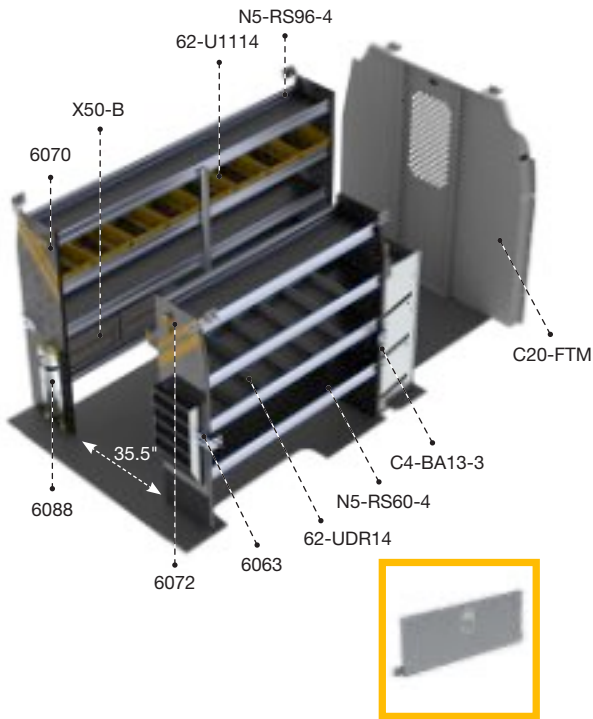

77-U1060

FTM-12

HVAC

| | | | | | |
|--|---------|--|---------|--|-------------|
| | Steel | | 148" | | Medium Roof |
| | 390 lbs | | 6.1 hrs | | Yes |

| Qty | Part # | Description |
|-----|------------------|------------------------------------------------------------|
| 1 | C4-BA13-3 | 3 Tier refrigerant rack for large bottles |
| 1 | 6063 | Paper holder, extra deep, 5 slots |
| 1 | 6070 | 6" Hook, 3" opening, painted |
| 1 | 6072 | 8" Swivel hook, 4" opening, painted |
| 1 | 6088 | Large aluminum bottle holder, with two black nylon straps |
| 8 | 62-U1114 | 14" Deep plastic bin |
| 2 | 62-UDR14 | Set of 5 dividers for a 14" shelf |
| 1 | 77-U1060 | Adjustable shelving door unit - 57" W - for 60" shelves |
| 1 | C20-FTM | Straight steel partition with perforated window, no access |
| 1 | N5-RS60-4 | Steel shelving unit, 14"D x 60" W x 62" H |
| 1 | N5-RS96-4 | Steel shelving unit, 14"D x 96" W x 62" H |
| 2 | X50-B | Compact 2-drawer unit |

FTH-12

HVAC

| | | | | | |
|--|---------|--|-----------------|--|-----------|
| | Steel | | 148", 148" Ext. | | High Roof |
| | 426 lbs | | 6.1 hrs | | Yes |

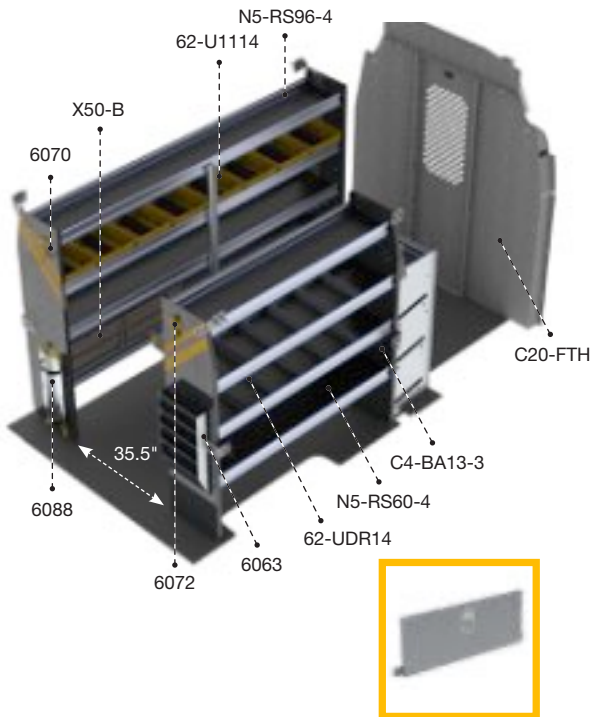

77-U1060

| Qty | Part # | Description |
|-----|------------------|------------------------------------------------------------|
| 1 | C4-BA13-3 | 3 Tier refrigerant rack for large bottles |
| 1 | 6063 | Paper holder, extra deep, 5 slots |
| 1 | 6070 | 6" Hook, 3" opening, painted |
| 1 | 6072 | 8" Swivel hook, 4" opening, painted |
| 1 | 6088 | Large aluminum bottle holder, with two black nylon straps |
| 8 | 62-U1114 | 14" Deep plastic bin |
| 2 | 62-UDR14 | Set of 5 dividers for a 14" shelf |
| 1 | 77-U1060 | Adjustable shelving door unit - 57" W - for 60" shelves |
| 1 | C20-FTH | Straight steel partition with perforated window, no access |
| 1 | N5-RS60-4 | Steel shelving unit, 14"D x 60" W x 62" H |
| 1 | N5-RS96-4 | Steel shelving unit, 14"D x 96" W x 62" H |
| 2 | X50-B | Compact 2-drawer unit |



FORD TRANSIT

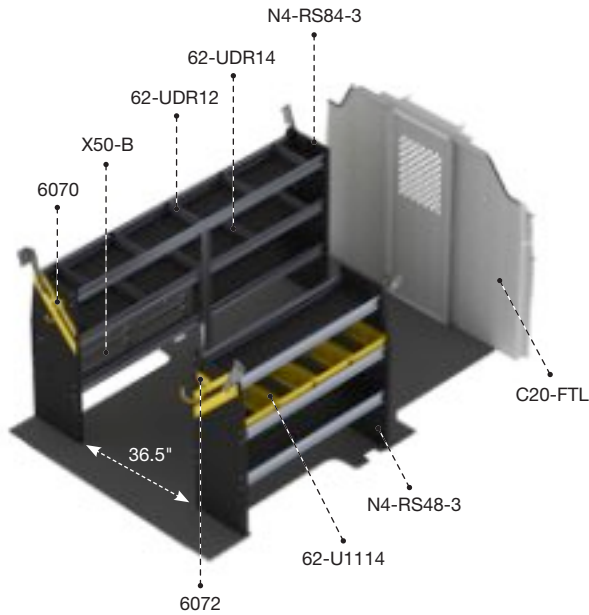

FTL-16 SERVICE

| | | |
|---------|------------|----------|
| Steel | 130", 148" | Low Roof |
| 273 lbs | 4.1 hrs | Yes |

| Qty | Part # | Description |
|-----|-----------|------------------------------------------------------------|
| 1 | 6070 | 6" Hook, 3" opening, painted |
| 1 | 6072 | 8" Swivel hook, 4" opening, painted |
| 4 | 62-U1114 | 14" Deep plastic bin |
| 1 | 62-UDR12 | Set of 5 dividers for a 12" shelf |
| 1 | 62-UDR14 | Set of 5 dividers for a 14" shelf |
| 1 | C20-FTL | Straight steel partition with perforated window, no access |
| 1 | N4-RS48-3 | Steel shelving unit, 14" D x 48" W x 44.5" H |
| 1 | N4-RS84-3 | Steel shelving unit, 14" D x 84" W x 44.5" H |
| 2 | X50-B | Compact 2-drawer unit |

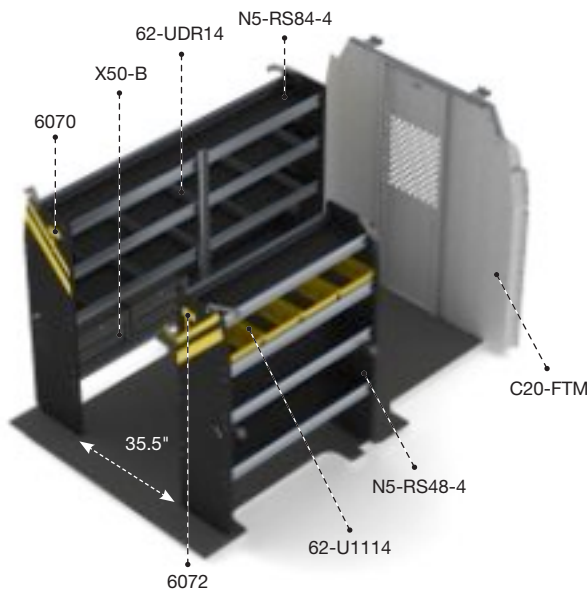

FTR-16 SERVICE

| | | |
|---------|---------|-------------|
| Steel | 130" | Medium Roof |
| 336 lbs | 4.6 hrs | Yes |

| Qty | Part # | Description |
|-----|-----------|------------------------------------------------------------|
| 1 | 6070 | 6" Hook, 3" opening, painted |
| 1 | 6072 | 8" Swivel hook, 4" opening, painted |
| 4 | 62-U1114 | 14" Deep plastic bin |
| 2 | 62-UDR14 | Set of 5 dividers for a 14" shelf |
| 1 | C20-FTM | Straight steel partition with perforated window, no access |
| 1 | N5-RS48-4 | Steel shelving unit, 14" D x 48" W x 62" H |
| 1 | N5-RS84-4 | Steel shelving unit, 14" D x 84" W x 62" H |
| 2 | X50-B | Compact 2-drawer unit |

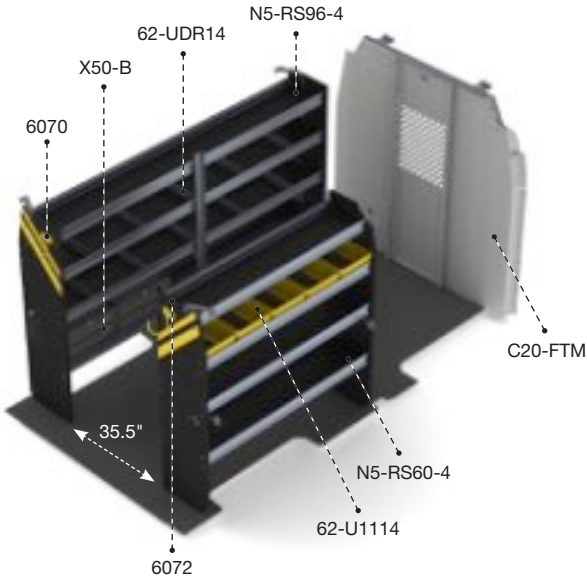

FTM-16 SERVICE

| | | |
|---------|---------|-------------|
| Steel | 148" | Medium Roof |
| 358 lbs | 4.6 hrs | Yes |

| Qty | Part # | Description |
|-----|-----------|------------------------------------------------------------|
| 1 | 6070 | 6" Hook, 3" opening, painted |
| 1 | 6072 | 8" Swivel hook, 4" opening, painted |
| 5 | 62-U1114 | 14" Deep plastic bin |
| 2 | 62-UDR14 | Set of 5 dividers for a 14" shelf |
| 1 | C20-FTM | Straight steel partition with perforated window, no access |
| 1 | N5-RS60-4 | Steel shelving unit, 14" D x 60" W x 62" H |
| 1 | N5-RS96-4 | Steel shelving unit, 14" D x 96" W x 62" H |
| 2 | X50-B | Compact 2-drawer unit |

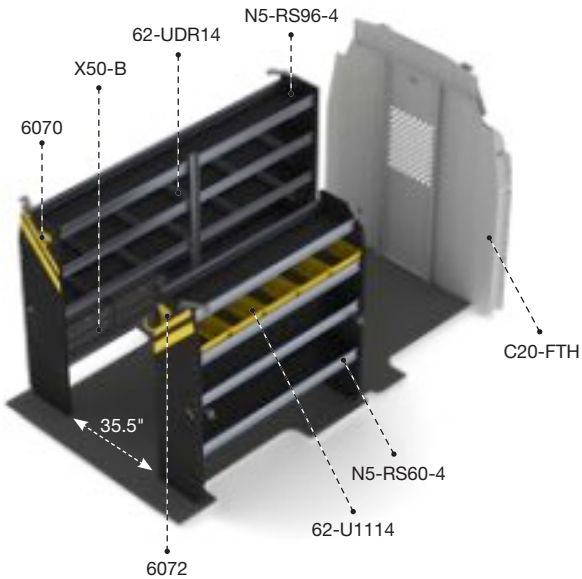

FTH-16 SERVICE

| | | |
|---------|-----------------|-----------|
| Steel | 148", 148" Ext. | High Roof |
| 373 lbs | 4.6 hrs | Yes |

| Qty | Part # | Description |
|-----|-----------|------------------------------------------------------------|
| 1 | 6070 | 6" Hook, 3" opening, painted |
| 1 | 6072 | 8" Swivel hook, 4" opening, painted |
| 5 | 62-U1114 | 14" Deep plastic bin |
| 2 | 62-UDR14 | Set of 5 dividers for a 14" shelf |
| 1 | C20-FTH | Straight steel partition with perforated window, no access |
| 1 | N5-RS60-4 | Steel shelving unit, 14" D x 60" W x 62" H |
| 1 | N5-RS96-4 | Steel shelving unit, 14" D x 96" W x 62" H |
| 2 | X50-B | Compact 2-drawer unit |



FORD TRANSIT

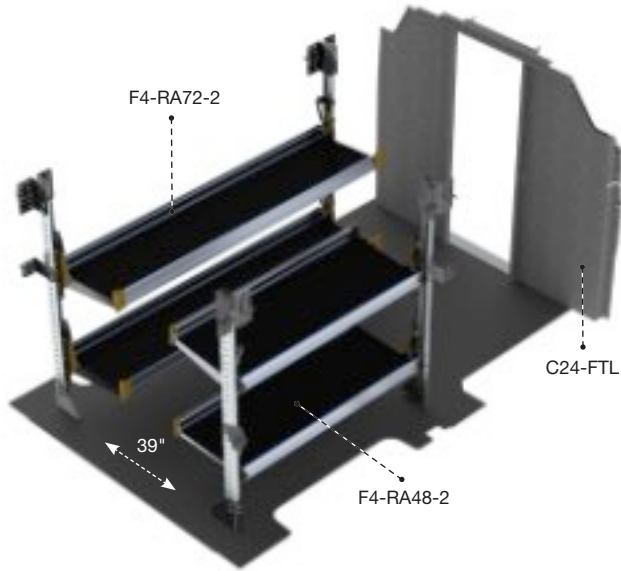

FTL-19 DELIVERY

| | | |
|----------|------------|----------|
| Aluminum | 130", 148" | Low Roof |
| 195 lbs | 4.4 hrs | Yes |

| Qty | Part # | Description |
|-----|------------------|-------------------------------------------------|
| 1 | C24-FTL | Straight walk through steel partition |
| 1 | F4-RA72-2 | Fold-away unit, 2 levels, 22" D x 72" W x 47" H |
| 1 | F4-RA48-2 | Fold-away unit, 2 levels, 22" D x 48" W x 47" H |

PACKAGES

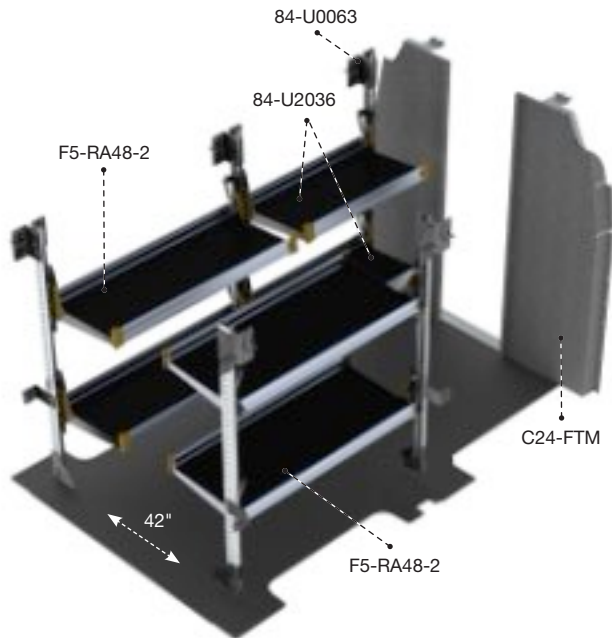

FTR-19 DELIVERY

| | | |
|----------|---------|-------------|
| Aluminum | 130" | Medium Roof |
| 259 lbs | 5.5 hrs | Yes |

| Qty | Part # | Description |
|-----|------------------|-------------------------------------------------|
| 1 | 84-U0063 | Post assembly for fold-away shelving, 63" |
| 2 | 84-U2036 | Fold-away shelf tray, 20" D x 36" W |
| 1 | C24-FTM | Straight walk through steel partition |
| 2 | F5-RA48-2 | Fold-away unit, 2 levels, 25" D x 48" W x 63" H |

FORD TRANSIT



PACKAGES

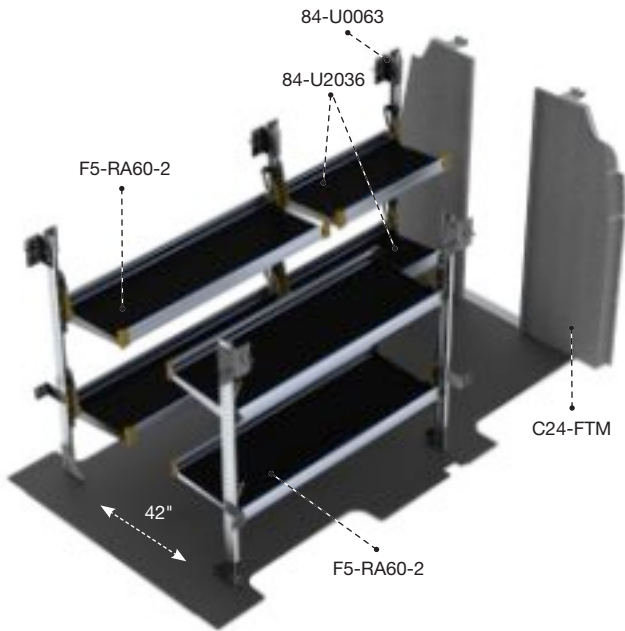

FTM-19 DELIVERY

| | | |
|----------|---------|-------------|
| Aluminum | 148" | Medium Roof |
| 271 lbs | 5.5 hrs | Yes |

| Qty | Part # | Description |
|-----|------------------|-------------------------------------------------|
| 1 | 84-U0063 | Post assembly for fold-away shelving, 63" |
| 2 | 84-U2036 | Fold-away shelf tray, 20" D x 36" W |
| 1 | C24-FTM | Straight walk through steel partition |
| 2 | F5-RA60-2 | Fold-away unit, 2 levels, 25" D x 60" W x 63" H |

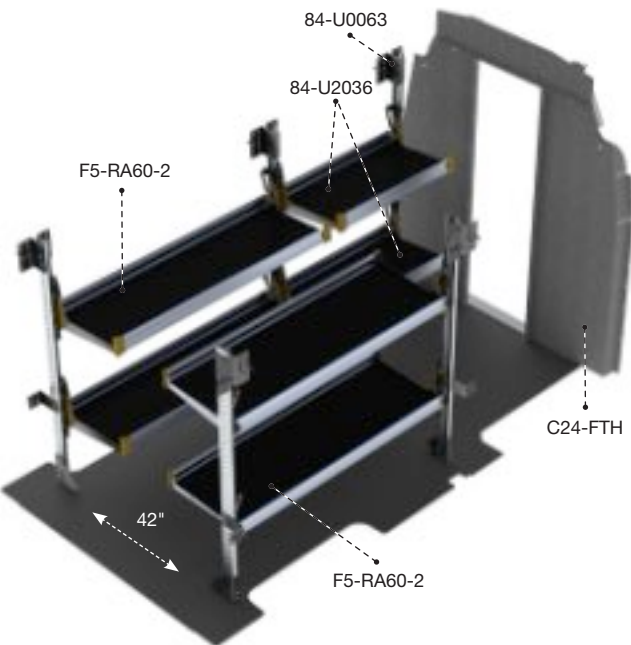

FTH-19 DELIVERY

| | | |
|----------|-----------------|-----------|
| Aluminum | 148", 148" Ext. | High Roof |
| 277 lbs | 5.5 hrs | Yes |

| Qty | Part # | Description |
|-----|------------------|-------------------------------------------------|
| 1 | 84-U0063 | Post assembly for fold-away shelving, 63" |
| 2 | 84-U2036 | Fold-away shelf tray, 20" D x 36" W |
| 1 | C24-FTH | Straight walk through steel partition |
| 2 | F5-RA60-2 | Fold-away unit, 2 levels, 25" D x 60" W x 63" H |



FORD TRANSIT

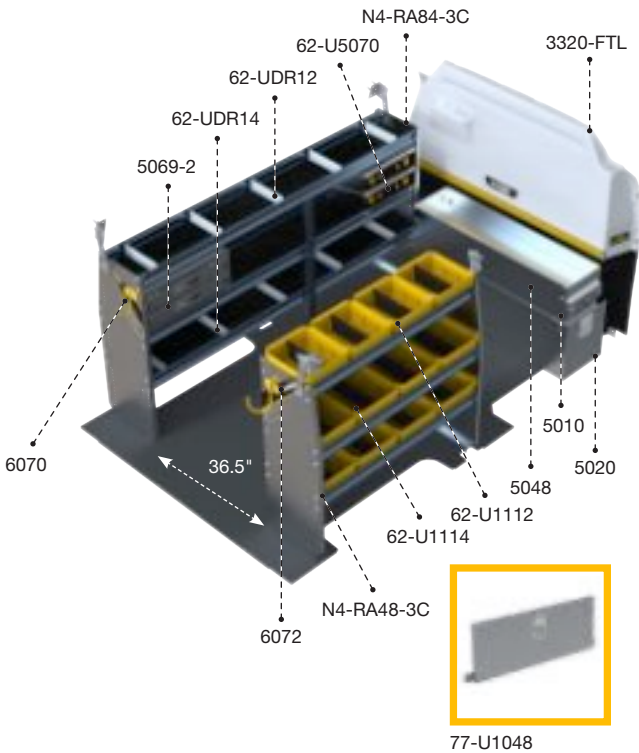

FTL-27 ALUMINUM

| | | | | | |
|--|----------|--|------------|--|----------|
| | Aluminum | | 130", 148" | | Low Roof |
| | 342 lbs | | 7.3 hrs | | Yes |

| Qty | Part # | Description |
|-----|------------|---------------------------------------------------------------|
| 1 | 3320-FTL | Max View Countoured safety partition |
| 1 | 5010 | Partslider 48" D |
| 1 | 5020 | Tool drawer 48" D x 14" W x 16" H |
| 1 | 5048 | Top edge |
| 1 | 5069-2 | 2 Drawer cabinet |
| 2 | 62-U5070 | Partskeeper carry case with holder |
| 1 | 6070 | 6" Hook, 3" opening, painted |
| 1 | 6072 | 8" Swivel hook, 4" opening, painted |
| 4 | 62-U1112 | 12" Deep plastic bin |
| 8 | 62-U1114 | 14" Deep plastic bin |
| 1 | 62-UDR12 | Set of 5 dividers for a 12" shelf |
| 1 | 62-UDR14 | Set of 5 dividers for a 14" shelf |
| 1 | 77-U1048 | Adjustable shelving door unit - 45" W - for 48" & 96" shelves |
| 1 | N4-RA48-3C | Composite Aluminum shelving unit, 14"D x 48" W x 44.5" H |
| 1 | N4-RA84-3C | Composite Aluminum shelving unit, 14"D x 84" W x 44.5" H |

PACKAGES

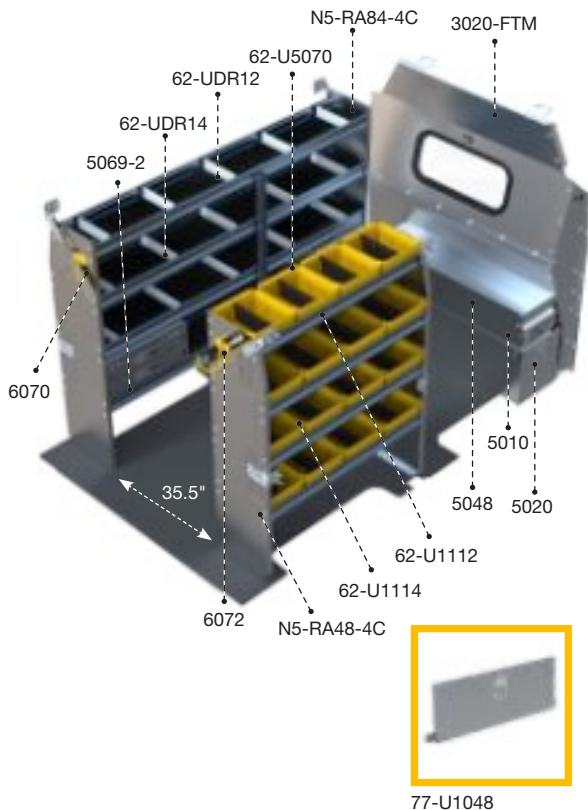

FTR-27 ALUMINUM

| | | | | | |
|--|----------|--|---------|--|-------------|
| | Aluminum | | 130" | | Medium Roof |
| | 426 lbs | | 7.3 hrs | | Yes |

| Qty | Part # | Description |
|-----|------------|---------------------------------------------------------------|
| 1 | 3020-FTM | Countoured safety partition with glass window |
| 1 | 5010 | Partslider 48" D |
| 1 | 5020 | Tool drawer 48" D x 14" W x 16" H |
| 1 | 5048 | Top edge |
| 1 | 5069-2 | 2 Drawer cabinet |
| 2 | 62-U5070 | Partskeeper carry case with holder |
| 1 | 6070 | 6" Hook, 3" opening, painted |
| 1 | 6072 | 8" Swivel hook, 4" opening, painted |
| 4 | 62-U1112 | 12" Deep plastic bin |
| 12 | 62-U1114 | 14" Deep plastic bin |
| 1 | 62-UDR12 | Set of 5 dividers for a 12" shelf |
| 2 | 62-UDR14 | Set of 5 dividers for a 14" shelf |
| 1 | 77-U1048 | Adjustable shelving door unit - 45" W - for 48" & 96" shelves |
| 1 | N5-RA48-4C | Composite Aluminum shelving unit, 14"D x 48" W x 62"H |
| 1 | N5-RA84-4C | Composite Aluminum shelving unit, 14" D x 84" W x 62"H |



ALUMINUM
FTM-27

FORD **TRANSIT**





FORD TRANSIT

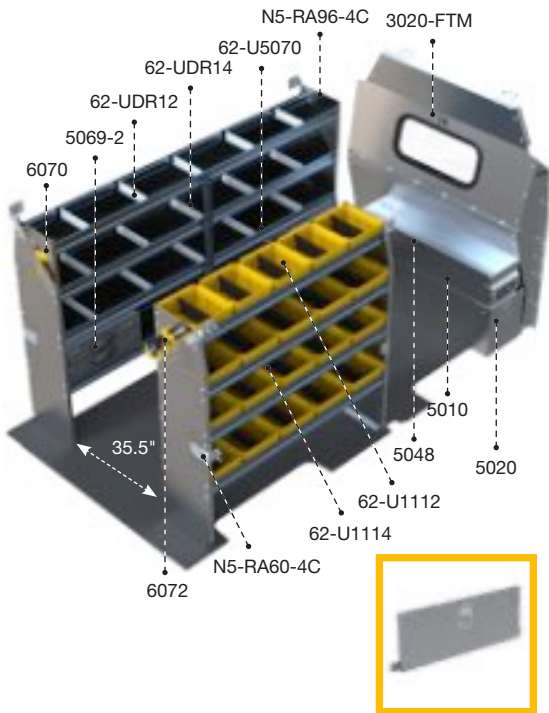

77-U1060

FTM-27
ALUMINUM

| | | |
|----------|---------|-------------|
| Aluminum | 148" | Medium Roof |
| 449 lbs | 7.3 hrs | Yes |

| Qty | Part # | Description |
|-----|-------------------|---------------------------------------------------------|
| 1 | 3020-FTM | Countoured safety partition with glass window |
| 1 | 5010 | Partslider 48" D |
| 1 | 5020 | Tool drawer 48" D x 14" W x 16" H |
| 1 | 5048 | Top edge |
| 1 | 5069-2 | 2 Drawer cabinet |
| 2 | 62-U5070 | Partskeeper cabinets |
| 1 | 6070 | 6" Hook, 3" opening, painted |
| 1 | 6072 | 8" Swivel hook, 4" opening, painted |
| 5 | 62-U1112 | 12" Deep plastic bin |
| 15 | 62-U1114 | 14" Deep plastic bin |
| 1 | 62-UDR12 | Set of 5 dividers for a 12" shelf |
| 2 | 62-UDR14 | Set of 5 dividers for a 14" shelf |
| 1 | 77-U1060 | Adjustable shelving door unit - 57" W - for 60" shelves |
| 1 | N5-RA60-4C | Composite Aluminum shelving unit, 14"D x 60" W x 62"H |
| 1 | N5-RA96-4C | Composite Aluminum shelving unit, 14"D x 96" W x 62"H |

PACKAGES

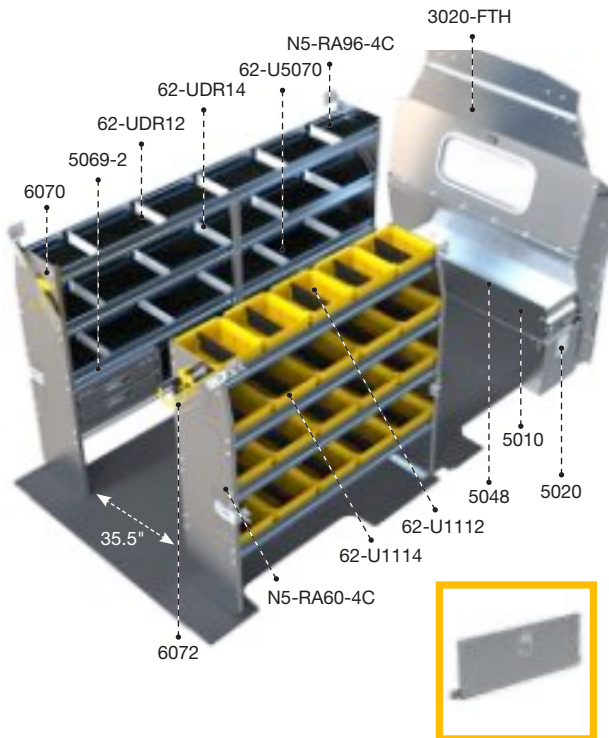

77-U1060

FTH-27
ALUMINUM

| | | |
|----------|-----------------|-----------|
| Aluminum | 148", 148" Ext. | High Roof |
| 454 lbs | 7.3 hrs | Yes |

| Qty | Part # | Description |
|-----|-------------------|---------------------------------------------------------|
| 1 | 3020-FTH | Countoured safety partition with glass window |
| 1 | 5010 | Partslider 48" D |
| 1 | 5020 | Tool drawer 48" D x 14" W x 16" H |
| 1 | 5048 | Top edge |
| 1 | 5069-2 | 2 Drawer cabinet |
| 2 | 62-U5070 | Partskeeper cabinets |
| 1 | 6070 | 6" Hook, 3" opening, painted |
| 1 | 6072 | 8" Swivel hook, 4" opening, painted |
| 5 | 62-U1112 | 12" Deep plastic bin |
| 15 | 62-U1114 | 14" Deep plastic bin |
| 1 | 62-UDR12 | Set of 5 dividers for a 12" shelf |
| 2 | 62-UDR14 | Set of 5 dividers for a 14" shelf |
| 1 | 77-U1060 | Adjustable shelving door unit - 57" W - for 60" shelves |
| 1 | N5-RA60-4C | Composite Aluminum shelving unit, 14"D x 60" W x 62"H |
| 1 | N5-RA96-4C | Composite Aluminum shelving unit, 14"D x 96" W x 62"H |

FORD TRANSIT CONNECT



PACKAGES

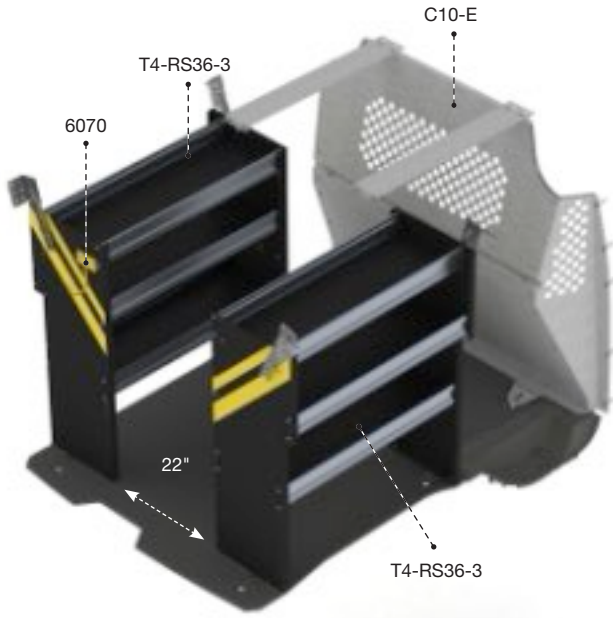

TCS-10 CONTRACTOR

| | | |
|-------------------------------------------------------------------------------------------|---------------------------------------------------------------------------------------------|----------------------------------------------------------------------------------------------|
|  Steel |  105" |  Standard |
|  149 lbs |  3.2 hrs |  Yes |

| Qty | Part # | Description |
|-----|------------------|--------------------------------------------------|
| 1 | 6070 | 6" Hook, 3" opening, painted |
| 1 | C10-E | Contoured steel partition with perforated window |
| 2 | T4-RS36-3 | Steel shelving unit, 14" D x 36" W x 41.5" H |

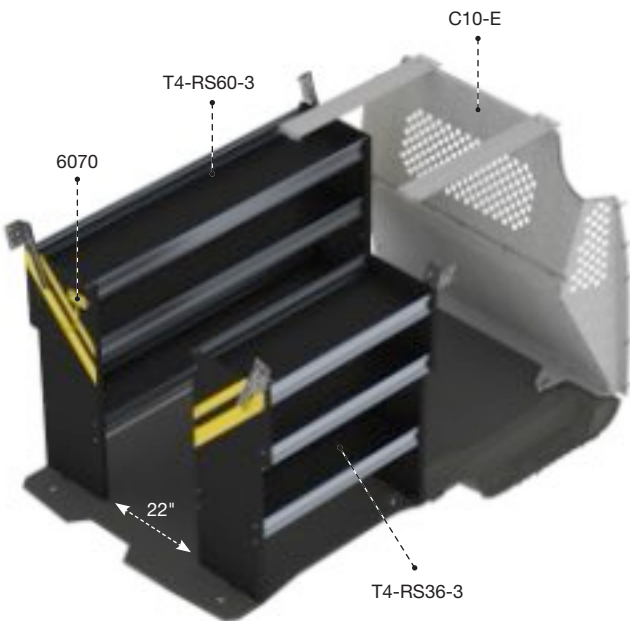

TCL-10 CONTRACTOR

| | | |
|---------------------------------------------------------------------------------------------|-----------------------------------------------------------------------------------------------|------------------------------------------------------------------------------------------------|
|  Steel |  120.5" |  Standard |
|  164 lbs |  3.2 hrs |  Yes |

| Qty | Part # | Description |
|-----|------------------|--------------------------------------------------|
| 1 | 6070 | 6" Hook, 3" opening, painted |
| 1 | C10-E | Contoured steel partition with perforated window |
| 1 | T4-RS36-3 | Steel shelving unit, 14" D x 36" W x 41.5" H |
| 1 | T4-RS60-3 | Steel shelving unit, 14" D x 60" W x 41.5" H |



FORD TRANSIT CONNECT

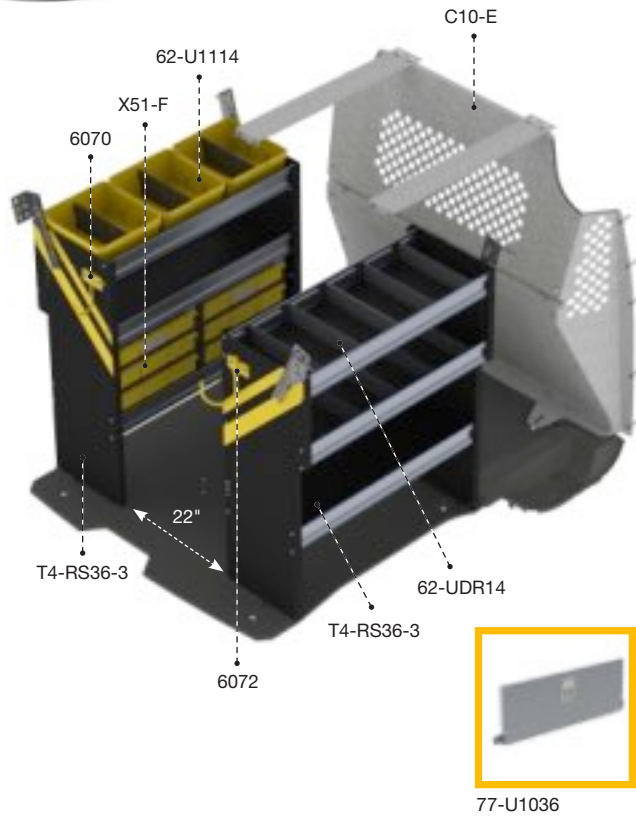

TCS-11
ELECTRICAL

| | | |
|---------|---------|----------|
| Steel | 105" | Standard |
| 223 lbs | 4.5 hrs | Yes |

| Qty | Part # | Description |
|-----|-----------|---------------------------------------------------------------|
| 1 | 6070 | 6" Hook, 3" opening, painted |
| 1 | 6072 | 8" Swivel hook, 4" opening, painted |
| 3 | 62-U1114 | 14" deep plastic bin |
| 2 | 62-UDR14 | Set of 5 dividers for a 14" Shelf |
| 1 | 77-U1036 | Adjustable shelving door unit - 33" W - for 36" & 72" shelves |
| 1 | C10-E | Contoured steel partition with perforated window |
| 2 | T4-RS36-3 | Steel Shelving unit, 14" D x 36" W x 41.5" H |
| 2 | X51-F | Compact 9-drawer unit |

PACKAGES

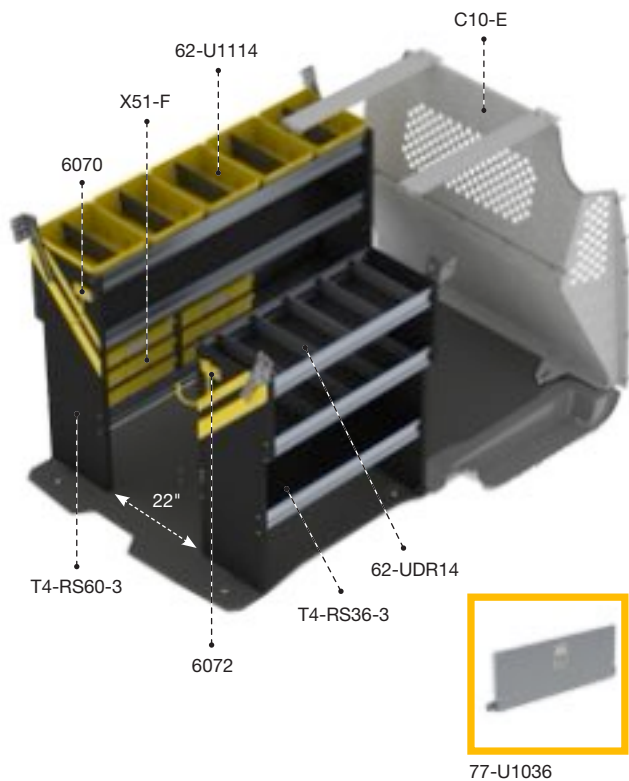

TCL-11
ELECTRICAL

| | | |
|---------|---------|----------|
| Steel | 120.5" | Standard |
| 164 lbs | 4.5 hrs | Yes |

| Qty | Part # | Description |
|-----|-----------|---------------------------------------------------------------|
| 1 | 6070 | 6" Hook, 3" opening, painted |
| 1 | 6072 | 8" Swivel hook, 4" opening, painted |
| 5 | 62-U1114 | 14" deep plastic bin |
| 2 | 62-UDR14 | Set of 5 dividers for a 14" Shelf |
| 1 | 77-U1036 | Adjustable shelving door unit - 33" W - for 36" & 72" shelves |
| 1 | C10-E | Contoured steel partition with perforated window |
| 1 | T4-RS36-3 | Steel Shelving unit, 14" D x 36" W x 41.5" H |
| 1 | T4-RS60-3 | Steel Shelving unit, 14" D x 60" W x 41.5" H |
| 2 | X51-F | Compact 9-drawer unit |



FORD TRANSIT CONNECT

PACKAGES

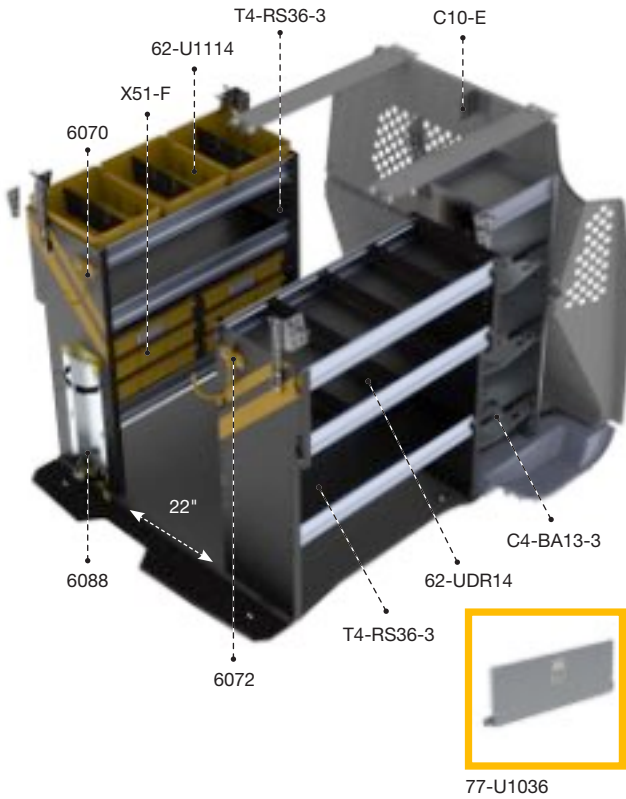

TCS-12 HVAC

| | | | | | |
|--|---------|--|---------|--|----------|
| | Steel | | 105" | | Standard |
| | 254 lbs | | 5.3 hrs | | Yes |

| Qty | Part # | Description |
|-----|------------------|---------------------------------------------------------------|
| 1 | C4-BA13-3 | 3 Tier refrigerant rack for large bottles |
| 1 | 6070 | 6" Hook, 3" opening, painted |
| 1 | 6072 | 8" Swivel hook, 4" opening, painted |
| 1 | 6088 | Large aluminum bottle holder, with two black nylon straps |
| 3 | 62-U1114 | 14" Deep plastic bin |
| 2 | 62-UDR14 | Set of 5 dividers for a 14" shelf |
| 1 | 77-U1036 | Adjustable shelving door unit - 33" W - for 36" & 72" shelves |
| 1 | C10-E | Contoured steel partition with perforated window |
| 2 | T4-RS36-3 | Steel shelving unit, 14" D x 36" W x 41.5" H |
| 2 | X51-F | Compact 9-drawer unit |

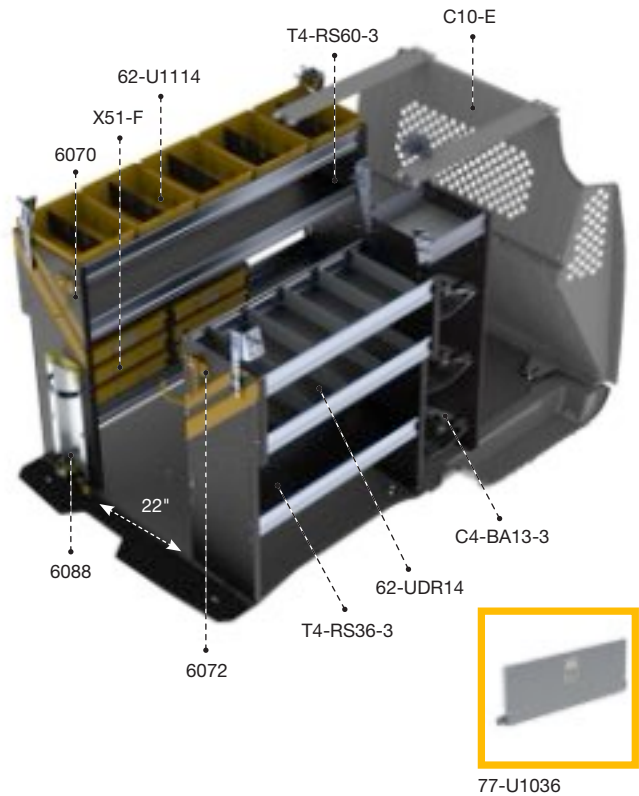

TCL-12 HVAC

| | | | | | |
|--|---------|--|---------|--|----------|
| | Steel | | 120.5" | | Standard |
| | 273 lbs | | 5.3 hrs | | Yes |

| Qty | Part # | Description |
|-----|------------------|---------------------------------------------------------------|
| 1 | C4-BA13-3 | 3 Tier refrigerant rack for large bottles |
| 1 | 6070 | 6" Hook, 3" opening, painted |
| 1 | 6072 | 8" Swivel hook, 4" opening, painted |
| 1 | 6088 | Large aluminum bottle holder, with two black nylon straps |
| 5 | 62-U1114 | 14" Deep plastic bin |
| 2 | 62-UDR14 | Set of 5 dividers for a 14" shelf |
| 1 | 77-U1036 | Adjustable shelving door unit - 33" W - for 36" & 72" shelves |
| 1 | C10-E | Contoured steel partition with perforated window |
| 1 | T4-RS36-3 | Steel shelving unit, 14" D x 36" W x 41.5" H |
| 1 | T4-RS60-3 | Steel Shelving unit, 14" D x 60" W x 41.5" H |
| 2 | X51-F | Compact 9-drawer unit |



FORD TRANSIT CONNECT

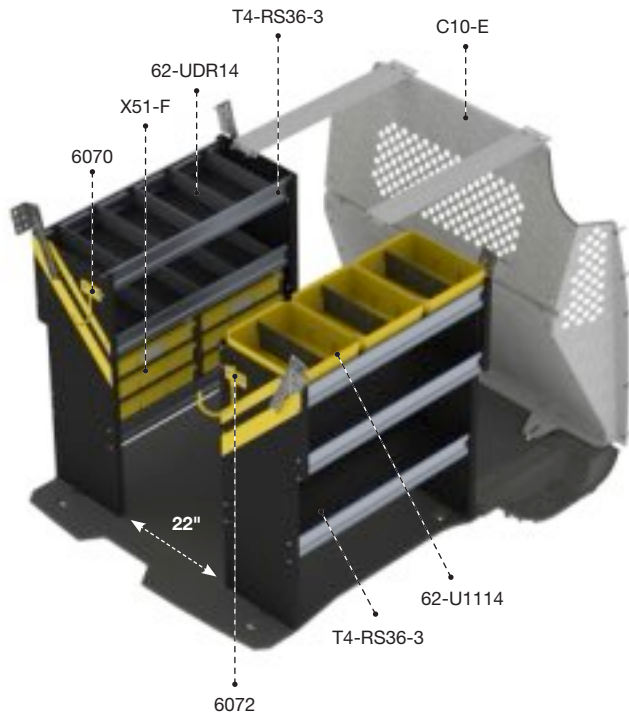

TCS-16 SERVICE

| | | |
|---------|-------|----------|
| Steel | 105" | Standard |
| 217 lbs | 4 hrs | Yes |

| Qty | Part # | Description |
|-----|-----------|--------------------------------------------------|
| 1 | 6070 | 6" Hook, 3" opening, painted |
| 1 | 6072 | 8" Swivel hook, 4" opening, painted |
| 3 | 62-U1114 | 14" deep plastic bin |
| 2 | 62-UDR14 | Set of 5 dividers for a 14" Shelf |
| 1 | C10-E | Contoured steel partition with perforated window |
| 2 | T4-RS36-3 | Steel Shelving unit, 14" D x 36" W x 41.5" H |
| 2 | X51-F | Compact 9-drawer unit |

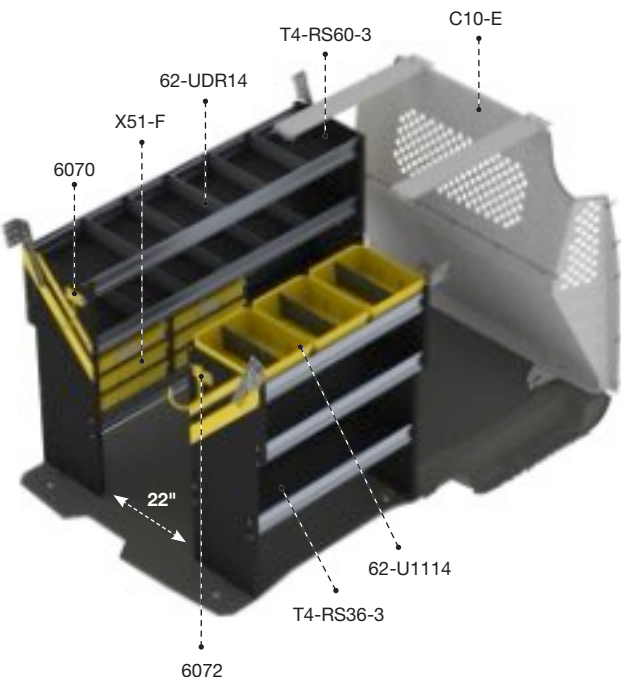

TCL-16 SERVICE

| | | |
|---------|--------|----------|
| Steel | 120.5" | Standard |
| 232 lbs | 4 hrs | Yes |

| Qty | Part # | Description |
|-----|-----------|--------------------------------------------------|
| 1 | 6070 | 6" Hook, 3" opening, painted |
| 1 | 6072 | 8" Swivel hook, 4" opening, painted |
| 3 | 62-U1114 | 14" deep plastic bin |
| 2 | 62-UDR14 | Set of 5 dividers for a 14" Shelf |
| 1 | C10-E | Contoured steel partition with perforated window |
| 1 | T4-RS36-3 | Steel Shelving unit, 14" D x 36" W x 41.5" H |
| 1 | T4-RS60-3 | Steel Shelving unit, 14" D x 60" W x 41.5" H |
| 2 | X51-F | Compact 9-drawer unit |

FORD TRANSIT CONNECT



PACKAGES

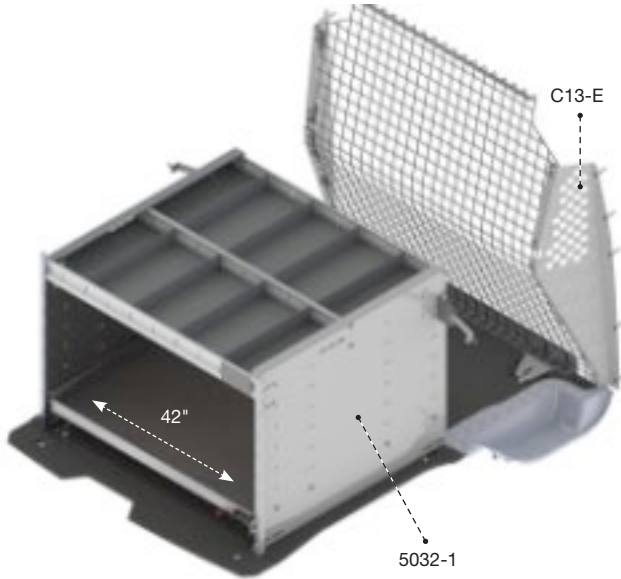

TCS-19 DELIVERY

| | | |
|----------|---------|----------|
| Aluminum | 105" | Standard |
| 126 lbs | 1.7 hrs | Yes |

| Qty | Part # | Description |
|-----|---------------|-------------------------------------------------------------|
| 1 | 5032-1 | Axess tray with 1 shelf and 1 drawer, 38" D x 45" W x 30" H |
| 1 | C13-E | Wire mesh partition |

Install kit # 6472 can be purchased separately.

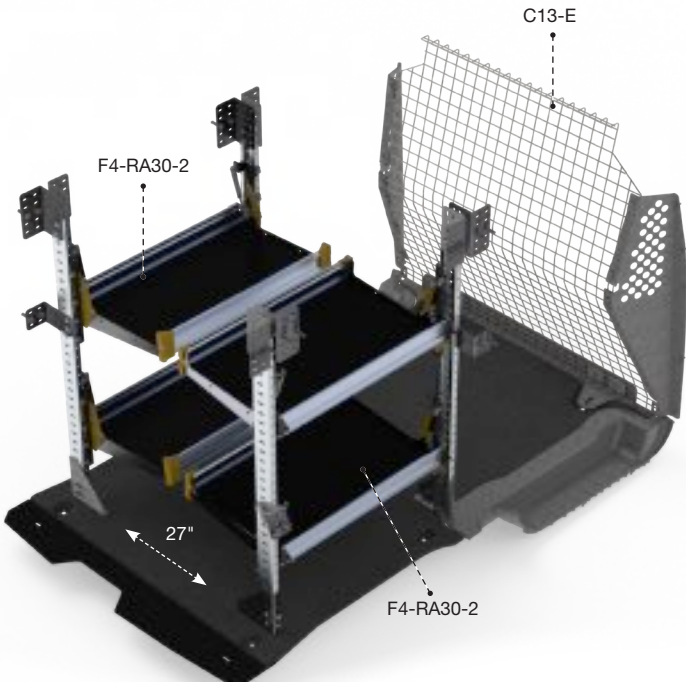

TCL-19 DELIVERY

| | | |
|----------|---------|----------|
| Aluminum | 120.5" | Standard |
| 154 lbs | 3.9 hrs | Yes |

| Qty | Part # | Description |
|-----|------------------|-------------------------------------------------|
| 1 | C13-E | Wire mesh partition |
| 2 | F4-RA30-2 | Fold-away unit, 2 levels, 22" D x 30" W x 47" H |



SERVICE **TCL-16**

FORD TRANSIT CONNECT



FORD TRANSIT CONNECT



PACKAGES

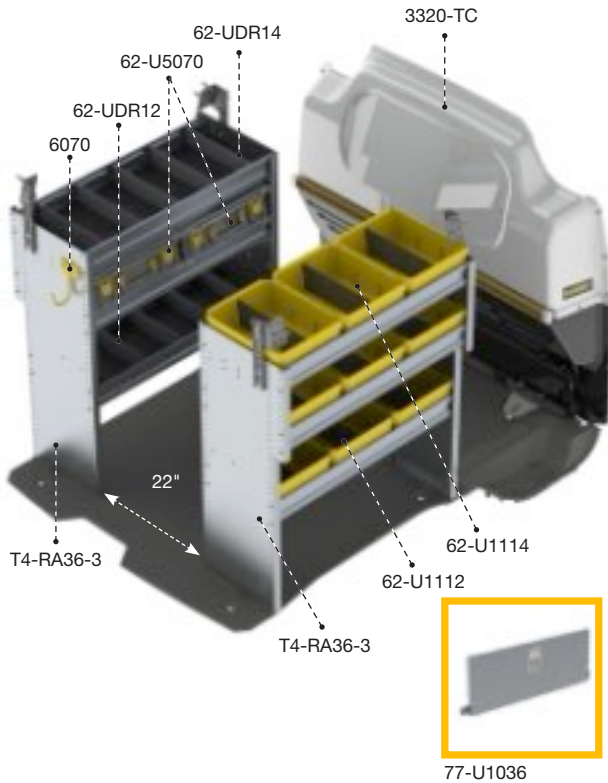

TCS-27 ALUMINUM

| | | |
|----------|---------|----------|
| Aluminum | 105" | Standard |
| 161 lbs | 4.3 hrs | Yes |

| Qty | Part # | Description |
|-----|-----------|---------------------------------------------------------------|
| 1 | 3320-TC | Max View countoured safety partition |
| 2 | 62-U5070 | Partskeeper carry case with holder |
| 1 | 6070 | 6" Hook, 3" opening, painted |
| 3 | 62-U1112 | 12" Deep plastic bin |
| 6 | 62-U1114 | 14" Deep plastic bin |
| 1 | 62-UDR12 | Set of 5 dividers for a 12" shelf |
| 1 | 62-UDR14 | Set of 5 dividers for a 14" shelf |
| 1 | 77-U1036 | Adjustable shelving door unit - 33" W - for 36" & 72" shelves |
| 2 | T4-RA36-3 | Aluminum shelving unit, 14" D x 36" W x 41.5" H |

TCL-27 ALUMINUM

| | | |
|----------|--------|----------|
| Aluminum | 120.5" | Standard |
| 240 lbs | 6 hrs | Yes |

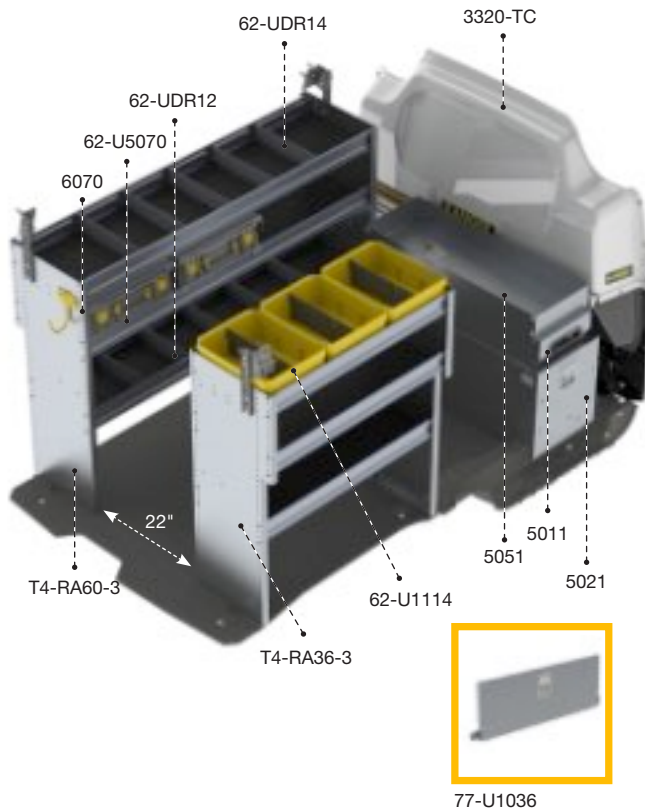

| Qty | Part # | Description |
|-----|-----------|---------------------------------------------------------------|
| 1 | 3320-TC | Max View countoured safety partition |
| 1 | 5011 | Partslider 36" D |
| 1 | 5021 | Tool drawer 36" D x 14" W x 16" H |
| 1 | 5051 | Top edge |
| 2 | 62-U5070 | Partskeeper carry case with holder |
| 1 | 6070 | 6" Hook, 3" opening, painted |
| 3 | 62-U1114 | 14" Deep plastic bin |
| 1 | 62-UDR12 | Set of 5 dividers for a 12" shelf |
| 1 | 62-UDR14 | Set of 5 dividers for a 14" shelf |
| 1 | 77-U1036 | Adjustable shelving door unit - 33" W - for 36" & 72" shelves |
| 1 | T4-RA36-3 | Aluminum shelving unit, 14" D x 36" W x 41.5" H |
| 1 | T4-RA60-3 | Aluminum shelving unit, 14" D x 60" W x 41.5" H |

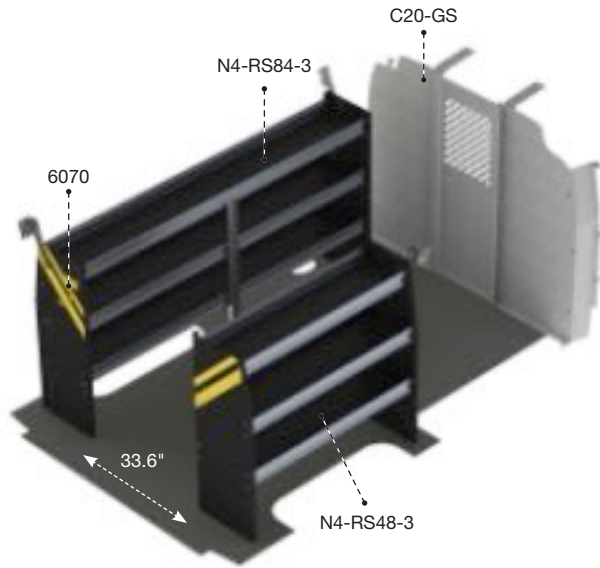

GSR-10 CONTRACTOR

| | | |
|---------|---------|----------|
| Steel | 135" | Standard |
| 203 lbs | 3.8 hrs | Yes |

| Qty | Part | Description |
|-----|-----------|------------------------------------------------------------|
| 1 | 6070 | 6" Hook, 3" opening, painted |
| 1 | C20-GS | Straight steel partition with perforated window, no access |
| 1 | N4-RS48-3 | Steel shelving unit, 14" D x 48" W x 44.5" H |
| 1 | N4-RS84-3 | Steel shelving unit, 14" D x 84" W x 44.5" H |

PACKAGES

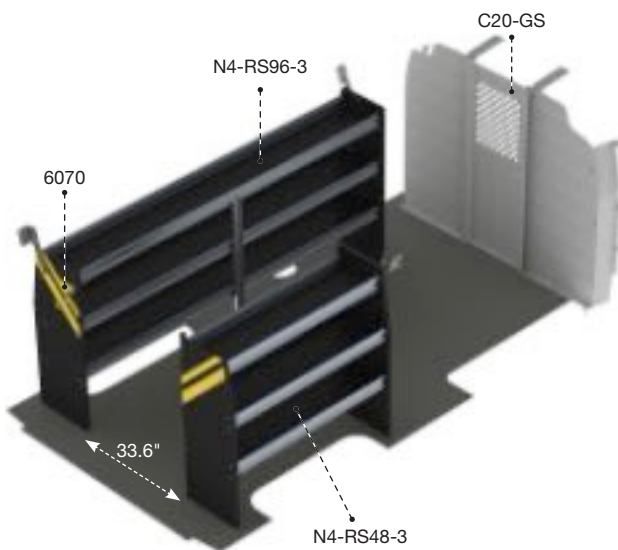

GSL-10 CONTRACTOR

| | | |
|---------|---------|----------|
| Steel | 155" | Standard |
| 211 lbs | 3.8 hrs | Yes |

| Qty | Part | Description |
|-----|-----------|------------------------------------------------------------|
| 1 | 6070 | 6" Hook, 3" opening, painted |
| 1 | C20-GS | Straight steel partition with perforated window, no access |
| 1 | N4-RS48-3 | Steel shelving unit, 14" D x 48" W x 44.5" H |
| 1 | N4-RS96-3 | Steel shelving unit, 14" D x 96" W x 44.5" H |

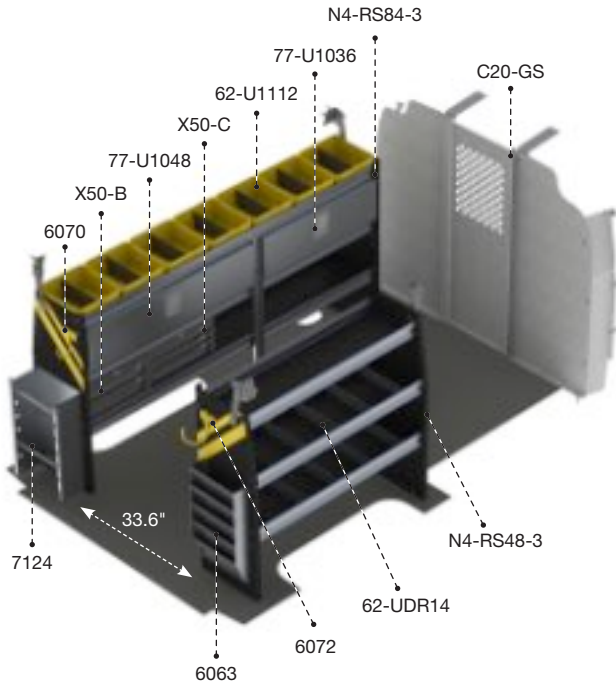

GSR-11 ELECTRICAL

| | | |
|---------|---------|----------|
| Steel | 135" | Standard |
| 311 lbs | 6.3 hrs | Yes |

| Qty | Part | Description |
|-----|-----------|---------------------------------------------------------------|
| 1 | 6063 | Paper holder, extra deep, 5 slots |
| 1 | 6070 | 6" Hook, 3" opening, painted |
| 1 | 6072 | 8" Swivel hook, 4" opening, painted |
| 1 | 7124 | Reel holder with two 5/8" diameter rods |
| 7 | 62-U1112 | 12" deep plastic bin |
| 2 | 62-UDR14 | Set of 5 dividers for a 14" Shelf |
| 1 | 77-U1036 | Adjustable shelving door unit - 33" W - for 36" & 72" shelves |
| 1 | 77-U1048 | Adjustable shelving door unit - 45" W - for 48" & 96" shelves |
| 1 | C20-GS | Straight steel partition with perforated window, no access |
| 1 | N4-RS48-3 | Steel shelving unit, 14" D x 48" W x 44.5" H |
| 1 | N4-RS84-3 | Steel shelving unit, 14" D x 84" W x 44.5" H |
| 1 | X50-B | Compact 2-drawer unit |
| 1 | X50-C | Compact 3-drawer unit |

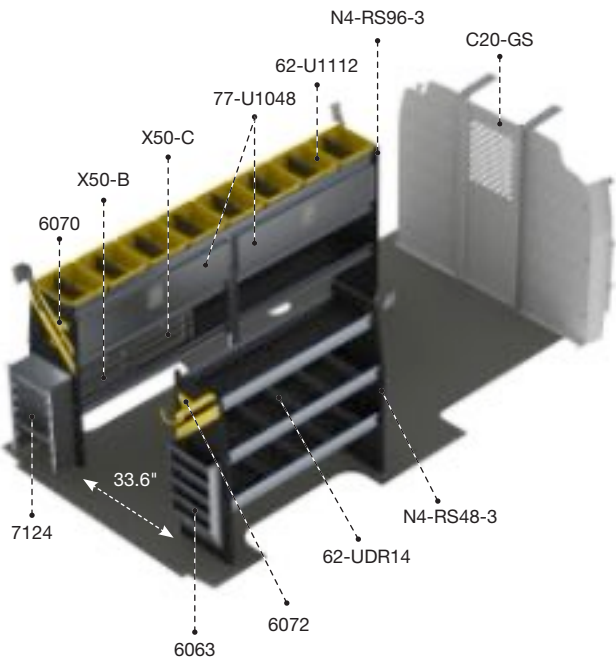

GSL-11 ELECTRICAL

| | | |
|---------|---------|----------|
| Steel | 155" | Standard |
| 322 lbs | 6.3 hrs | Yes |

| Qty | Part | Description |
|-----|-----------|---------------------------------------------------------------|
| 1 | 6063 | Paper holder, extra deep, 5 slots |
| 1 | 6070 | 6" Hook, 3" opening, painted |
| 1 | 6072 | 8" Swivel hook, 4" opening, painted |
| 1 | 7124 | Reel holder with two 5/8" diameter rods |
| 8 | 62-U1112 | 12" deep plastic bin |
| 2 | 62-UDR14 | Set of 5 dividers for a 14" Shelf |
| 2 | 77-U1048 | Adjustable shelving door unit - 45" W - for 48" & 96" shelves |
| 1 | C20-GS | Straight steel partition with perforated window, no access |
| 1 | N4-RS48-3 | Steel shelving unit, 14" D x 48" W x 44.5" H |
| 1 | N4-RS96-3 | Steel shelving unit, 14" D x 96" W x 44.5" H |
| 1 | X50-B | Compact 2-drawer unit |
| 1 | X50-C | Compact 3-drawer unit |



HVAC **GSR-12**

GMC SAVANA



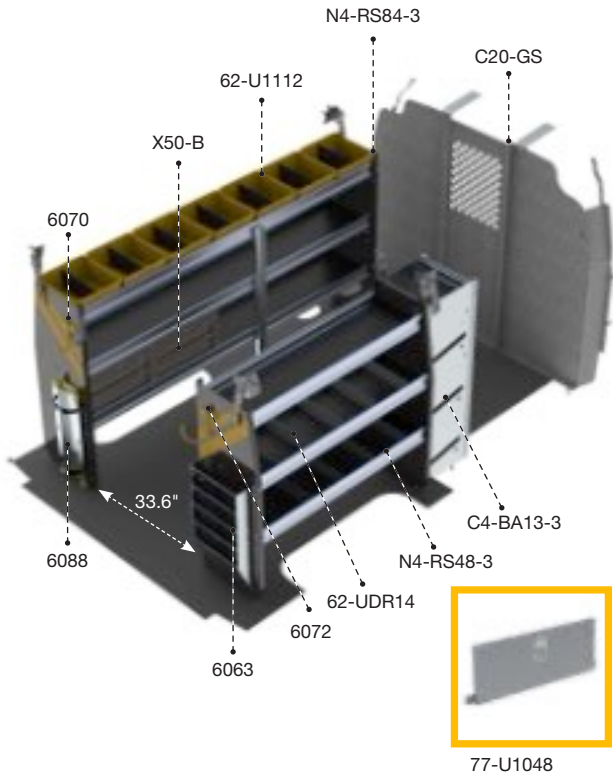

GSR-12 HVAC

| | | | | | |
|--|---------|--|---------|--|----------|
| | Steel | | 135" | | Standard |
| | 320 lbs | | 6.1 hrs | | Yes |

| Qty | Part | Description |
|-----|------------------|---------------------------------------------------------------|
| 1 | C4-BA13-3 | 3 Tier refrigerant rack for large bottles |
| 1 | 6063 | Paper holder, extra deep, 5 slots |
| 1 | 6070 | 6" Hook, 3" opening, painted |
| 1 | 6072 | 8" Swivel hook, 4" opening, painted |
| 1 | 6088 | Large aluminum bottle holder, with two black nylon straps |
| 7 | 62-U1112 | 12" deep plastic bin |
| 2 | 62-UDR14 | Set of 5 dividers for a 14" Shelf |
| 1 | 77-U1048 | Adjustable shelving door unit - 45" W - for 48" & 96" shelves |
| 1 | C20-GS | Straight steel partition with perforated window, no access |
| 1 | N4-RS48-3 | Steel shelving unit, 14" D x 48" W x 44.5" H |
| 1 | N4-RS84-3 | Steel shelving unit, 14" D x 84" W x 44.5" H |
| 2 | X50-B | Compact 2-drawer unit |

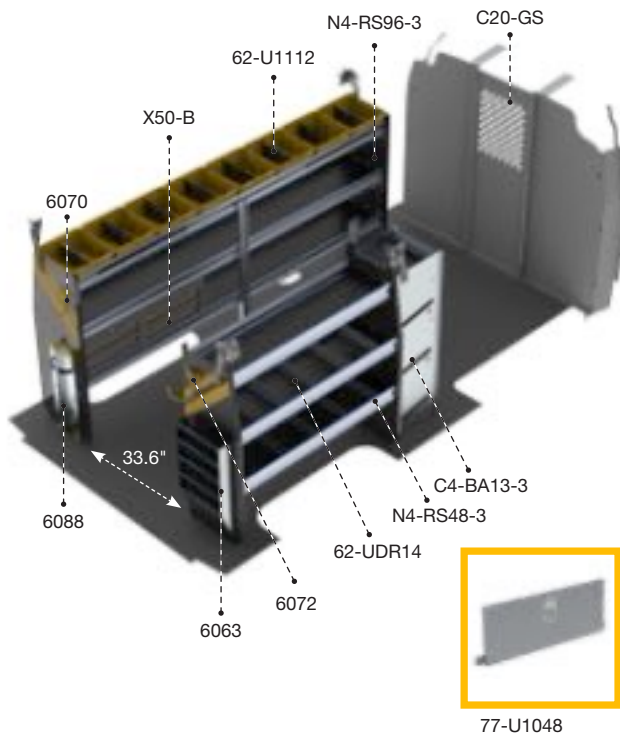

GSL-12 HVAC

| | | | | | |
|--|---------|--|---------|--|----------|
| | Steel | | 155" | | Standard |
| | 330 lbs | | 6.1 hrs | | Yes |

| Qty | Part | Description |
|-----|------------------|---------------------------------------------------------------|
| 1 | C4-BA13-3 | 3 Tier refrigerant rack for large bottles |
| 1 | 6063 | Paper holder, extra deep, 5 slots |
| 1 | 6070 | 6" Hook, 3" opening, painted |
| 1 | 6072 | 8" Swivel hook, 4" opening, painted |
| 1 | 6088 | Large aluminum bottle holder, with two black nylon straps |
| 8 | 62-U1112 | 12" deep plastic bin |
| 2 | 62-UDR14 | Set of 5 dividers for a 14" Shelf |
| 1 | 77-U1048 | Adjustable shelving door unit - 45" W - for 48" & 96" shelves |
| 1 | C20-GS | Straight steel partition with perforated window, no access |
| 1 | N4-RS48-3 | Steel shelving unit, 14" D x 48" W x 44.5" H |
| 1 | N4-RS96-3 | Steel shelving unit, 14" D x 96" W x 44.5" H |
| 2 | X50-B | Compact 2-drawer unit |

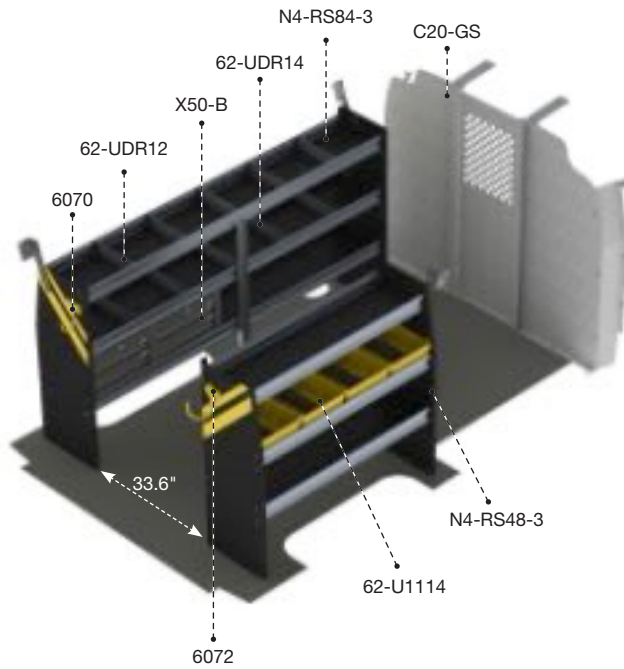

GSR-16 SERVICE

| | | |
|---------|---------|----------|
| Steel | 135" | Standard |
| 270 lbs | 4.6 hrs | Yes |

| Qty | Part | Description |
|-----|-----------|------------------------------------------------------------|
| 1 | 6070 | 6" Hook, 3" opening, painted |
| 1 | 6072 | 8" Swivel hook, 4" opening, painted |
| 4 | 62-U1114 | 14" deep plastic bin |
| 1 | 62-UDR12 | Set of 5 dividers for a 12" Shelf |
| 1 | 62-UDR14 | Set of 5 dividers for a 14" Shelf |
| 1 | C20-GS | Straight steel partition with perforated window, no access |
| 1 | N4-RS48-3 | Steel shelving unit, 14" D x 48" W x 44.5" H |
| 1 | N4-RS84-3 | Steel shelving unit, 14" D x 84" W x 44.5" H |
| 2 | X50-B | Compact 2-drawer unit |

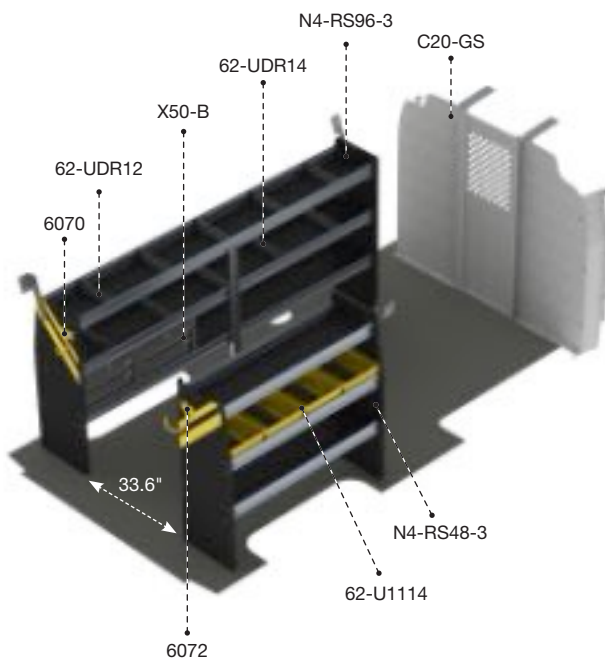

GSL-16 SERVICE

| | | |
|---------|---------|----------|
| Steel | 155" | Standard |
| 278 lbs | 4.6 hrs | Yes |

| Qty | Part | Description |
|-----|-----------|------------------------------------------------------------|
| 1 | 6070 | 6" Hook, 3" opening, painted |
| 1 | 6072 | 8" Swivel hook, 4" opening, painted |
| 4 | 62-U1114 | 14" deep plastic bin |
| 1 | 62-UDR12 | Set of 5 dividers for a 12" Shelf |
| 1 | 62-UDR14 | Set of 5 dividers for a 14" Shelf |
| 1 | C20-GS | Straight steel partition with perforated window, no access |
| 1 | N4-RS48-3 | Steel shelving unit, 14" D x 48" W x 44.5" H |
| 1 | N4-RS96-3 | Steel shelving unit, 14" D x 96" W x 44.5" H |
| 2 | X50-B | Compact 2-drawer unit |

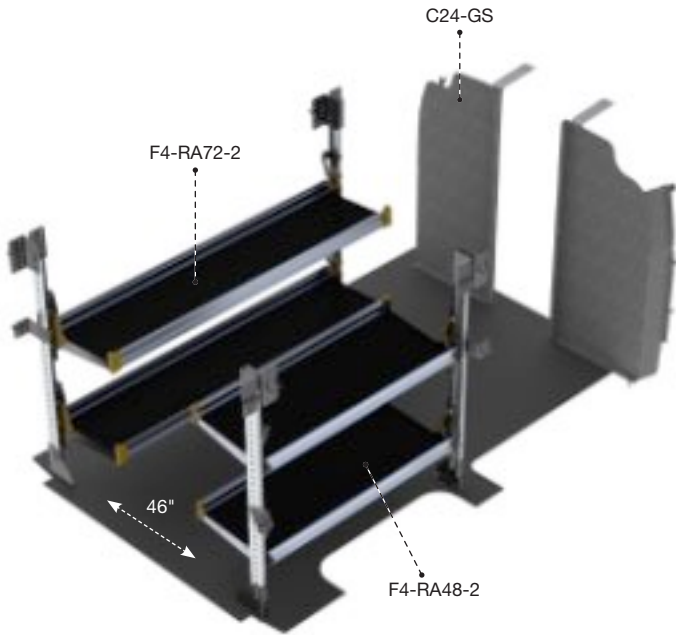

GSR-19 DELIVERY

| | | |
|----------|---------|----------|
| Aluminum | 135" | Standard |
| 195 lbs | 4.2 hrs | Yes |

| Qty | Part | Description |
|-----|------------------|-------------------------------------------------|
| 1 | C24-GS | Straight walk through steel partition |
| 1 | F4-RA72-2 | Fold-away unit, 2 levels, 22" D x 72" W x 47" H |
| 1 | F4-RA48-2 | Fold-away unit, 2 levels, 22" D x 48" W x 47" H |

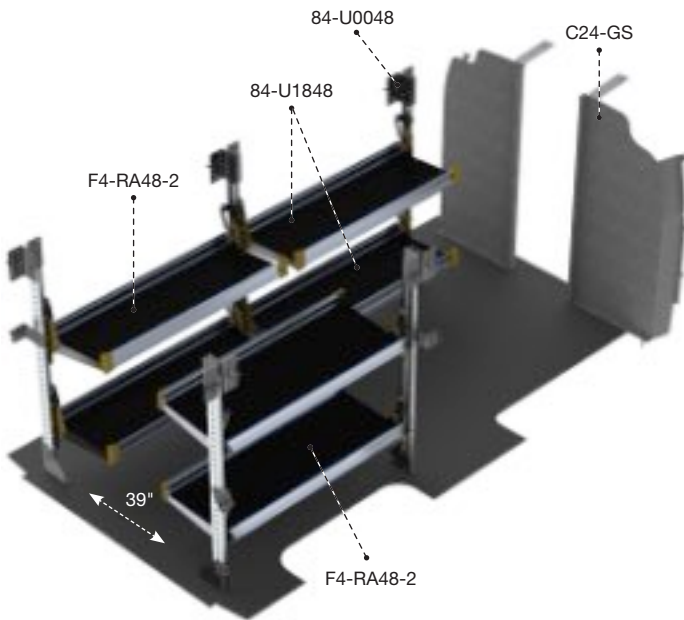

GSL-19 DELIVERY

| | | |
|----------|---------|----------|
| Aluminum | 155" | Standard |
| 239 lbs | 5.3 hrs | Yes |

| Qty | Part | Description |
|-----|------------------|-------------------------------------------------|
| 1 | 84-U0048 | Post assembly for fold-away shelving, 48" |
| 2 | 84-U1848 | Fold-away shelf tray, 18" D x 48" W |
| 1 | C24-GS | Straight walk through steel partition |
| 2 | F4-RA48-2 | Fold-away unit, 2 levels, 22" D x 48" W x 47" H |

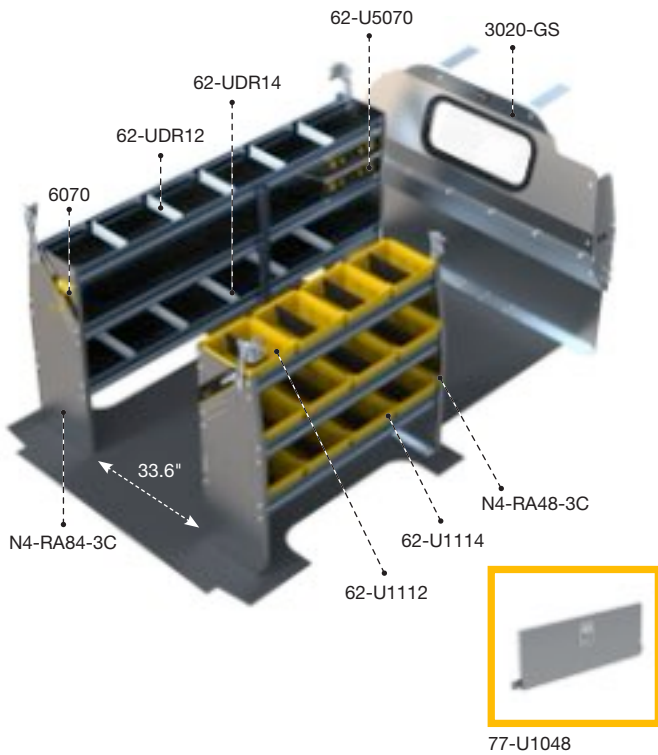

GSR-27 ALUMINUM

| | | |
|----------|---------|----------|
| Aluminum | 135" | Standard |
| 205 lbs | 4.4 hrs | Yes |

| Qty | Part | Description |
|-----|-------------------|---------------------------------------------------------------|
| 1 | 3020-GS | Countoured safety partition with glass window |
| 2 | 62-U5070 | Partskeeper carry case with holder |
| 1 | 6070 | 6" Hook, 3" opening, painted |
| 4 | 62-U1112 | 12" deep plastic bin |
| 8 | 62-U1114 | 14" deep plastic bin |
| 1 | 62-UDR12 | Set of 5 dividers for a 12" Shelf |
| 1 | 62-UDR14 | Set of 5 dividers for a 14" Shelf |
| 1 | 77-U1048 | Adjustable shelving door unit - 45" W - for 48" & 96" shelves |
| 1 | N4-RA48-3C | Composite Aluminum shelving unit, 14" D x 48" W x 44.5" H |
| 1 | N4-RA84-3C | Composite Aluminum shelving unit, 14" D x 84" W x 44.5" H |

PACKAGES

GSL-27 ALUMINUM

| | | |
|----------|---------|----------|
| Aluminum | 155" | Standard |
| 311 lbs | 6.1 hrs | Yes |

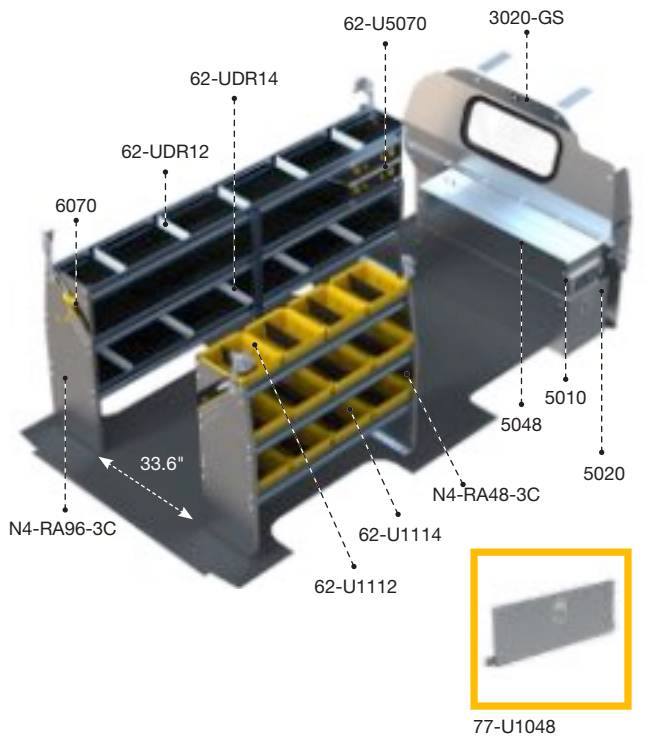

| Qty | Part | Description |
|-----|-------------------|---------------------------------------------------------------|
| 1 | 3020-GS | Countoured safety partition with glass window |
| 1 | 5010 | Partslider drawer 48" D |
| 1 | 5020 | Tool Drawer 48" D x 14" W x 16" H |
| 1 | 5048 | Top edge |
| 2 | 62-U5070 | Partskeeper carry case with holder |
| 1 | 6070 | 6" Hook, 3" opening, painted |
| 4 | 62-U1112 | 12" deep plastic bin |
| 8 | 62-U1114 | 14" deep plastic bin |
| 1 | 62-UDR12 | Set of 5 dividers for a 12" Shelf |
| 1 | 62-UDR14 | Set of 5 dividers for a 14" Shelf |
| 1 | 77-U1048 | Adjustable shelving door unit - 45" W - for 48" & 96" shelves |
| 1 | N4-RA48-3C | Composite Aluminum shelving unit, 14" D x 48" W x 44.5" H |
| 1 | N4-RA96-3C | Composite Aluminum shelving unit, 14" D x 96" W x 44.5" H |

MERCEDES-BENZ METRIS



PACKAGES

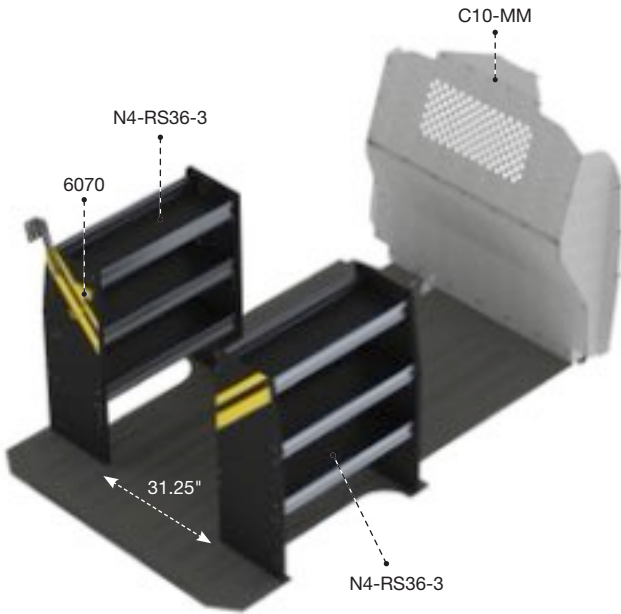

MMR-10 CONTRACTOR

| | | |
|---------|------------|----------|
| Steel | 126", 135" | Standard |
| 164 lbs | 3.2 hrs | Yes |

| Qty | Part # | Description |
|-----|-----------|--------------------------------------------------|
| 1 | 6070 | 6" Hook, 3" opening, painted |
| 1 | C10-MM | Contoured steel partition with perforated window |
| 2 | N4-RS36-3 | Steel shelving units, 14" D x 36" W x 46.5" H |

The Base package is designed to fit in a Metris with dual sliding doors.

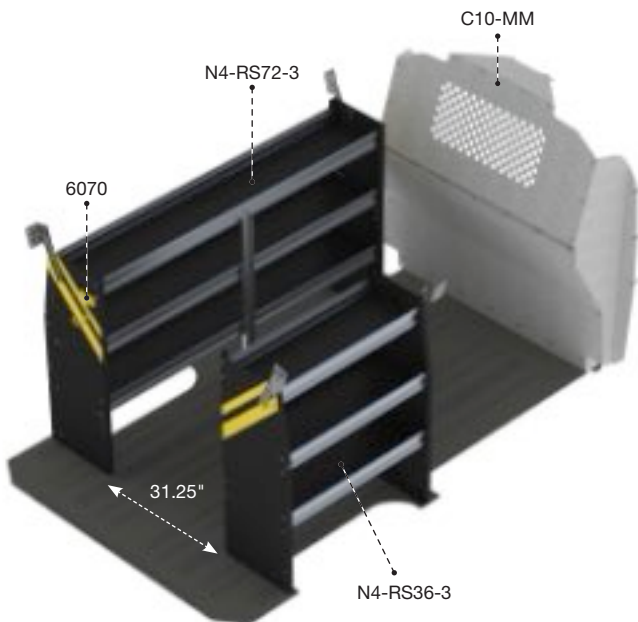

MML-10 CONTRACTOR

| | | |
|---------|------------|----------|
| Steel | 126", 135" | Standard |
| 189 lbs | 3.3 hrs | Yes |

| Qty | Part # | Description |
|-----|-----------|--------------------------------------------------|
| 1 | 6070 | 6" Hook, 3" opening, painted |
| 1 | C10-MM | Contoured steel partition with perforated window |
| 1 | N4-RS36-3 | Steel shelving unit, 14" D x 36" W x 46.5" H |
| 1 | N4-RS72-3 | Steel shelving unit, 14" D x 72" W x 46.5" H |

The Deluxe package is designed to fit in a Metris with a single sliding door.



MERCEDES-BENZ METRIS

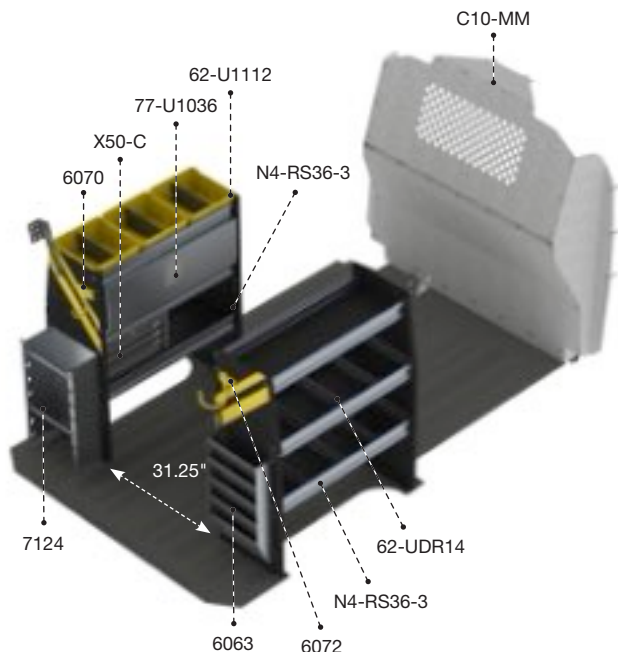

MMR-11 ELECTRICAL

| | | |
|---------|------------|----------|
| Steel | 126", 135" | Standard |
| 229 lbs | 4.9 hrs | Yes |

| Qty | Part # | Description |
|-----|-----------|---------------------------------------------------------------|
| 1 | 6063 | Paper holder, extra deep, 5 slots |
| 1 | 6070 | 6" Hook, 3" opening, painted |
| 1 | 6072 | 8" Swivel hook, 4" opening, painted |
| 3 | 62-U1112 | 12" Deep plastic bin |
| 2 | 62-UDR14 | Set of 5 dividers for a 14" shelf |
| 1 | 7124 | Reel holder with two 5/8" diameter rods |
| 1 | 77-U1036 | Adjustable shelving door unit - 33" W - for 36" & 72" shelves |
| 1 | C10-MM | Contoured steel partition with perforated window |
| 2 | N4-RS36-3 | Steel shelving units, 14" D x 36" W x 46.5" H |
| 1 | X50-C | Compact 3-drawer unit |

The Base package is designed to fit in a Metris with dual sliding doors.

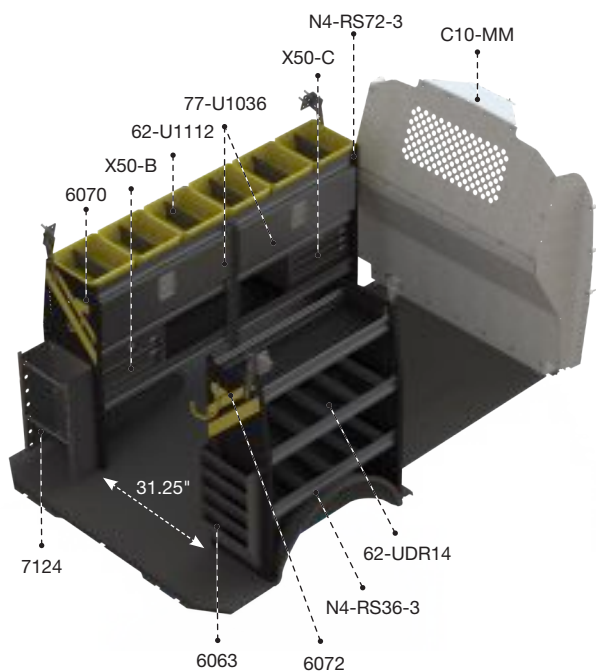

MML-11 ELECTRICAL

| | | |
|---------|------------|----------|
| Steel | 126", 135" | Standard |
| 293 lbs | 5.8 hrs | Yes |

| Qty | Part # | Description |
|-----|-----------|---------------------------------------------------------------|
| 1 | 6063 | Paper holder, extra deep, 5 slots |
| 1 | 6070 | 6" Hook, 3" opening, painted |
| 1 | 6072 | 8" Swivel hook, 4" opening, painted |
| 6 | 62-U1112 | 12" Deep plastic bin |
| 2 | 62-UDR14 | Set of 5 dividers for a 14" shelf |
| 1 | 7124 | Reel holder with two 5/8" diameter rods |
| 2 | 77-U1036 | Adjustable shelving door unit - 33" W - for 36" & 72" shelves |
| 1 | C10-MM | Contoured steel partition with perforated window |
| 1 | N4-RS36-3 | Steel shelving unit, 14" D x 36" W x 44.5" H |
| 1 | N4-RS72-3 | Steel shelving unit, 14" D x 72" W x 44.5" H |
| 1 | X50-B | Compact 2-drawer unit |
| 1 | X50-C | Compact 3-drawer unit |

The Deluxe package is designed to fit in a Metris with a single sliding door.

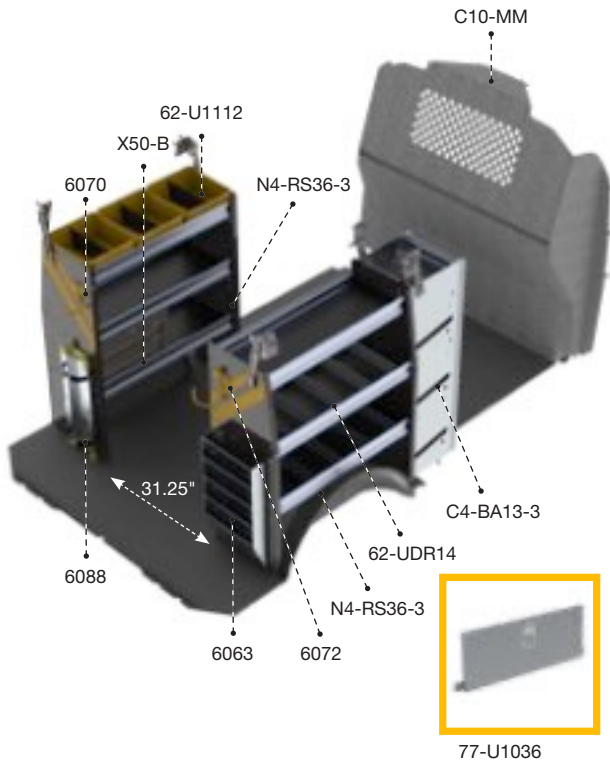

MMR-12 HVAC

| | | | | | |
|--|---------|--|------------|--|----------|
| | Steel | | 126", 135" | | Standard |
| | 246 lbs | | 5.2 hrs | | Yes |

| Qty | Part # | Description |
|-----|------------------|---------------------------------------------------------------|
| 1 | C4-BA13-3 | 3 Tier refrigerant rack for large bottles |
| 1 | 6063 | Paper holder, extra deep, 5 slots |
| 1 | 6070 | 6" Hook, 3" opening, painted |
| 1 | 6072 | 8" Swivel hook, 4" opening, painted |
| 1 | 6088 | Large aluminum bottle holder, with two black nylon straps |
| 3 | 62-U1112 | 12" deep plastic bin |
| 2 | 62-UDR14 | Set of 5 dividers for a 14" Shelf |
| 1 | 77-U1036 | Adjustable shelving door unit - 33" W - for 36" & 72" shelves |
| 1 | C10-MM | Contoured steel partition with perforated window |
| 2 | N4-RS36-3 | Steel shelving units, 14" D x 36" W x 44.5" H |
| 1 | X50-B | 2 Drawer Cabinet |

The Base package is designed to fit in a Metris with dual sliding doors.

MML-12 HVAC

| | | | | | |
|--|---------|--|------------|--|----------|
| | Steel | | 126", 135" | | Standard |
| | 303 lbs | | 5.6 hrs | | Yes |

| Qty | Part # | Description |
|-----|------------------|---------------------------------------------------------------|
| 1 | C4-BA13-3 | 3 Tier refrigerant rack for large bottles |
| 1 | 6063 | Paper holder, extra deep, 5 slots |
| 1 | 6070 | 6" Hook, 3" opening, painted |
| 1 | 6072 | 8" Swivel hook, 4" opening, painted |
| 1 | 6088 | Large aluminum bottle holder, with two black nylon straps |
| 6 | 62-U1112 | 12" deep plastic bin |
| 2 | 62-UDR14 | Set of 5 dividers for a 14" Shelf |
| 1 | 77-U1036 | Adjustable shelving door unit - 33" W - for 36" & 72" shelves |
| 1 | C10-MM | Contoured steel partition with perforated window |
| 1 | N4-RS36-3 | Steel shelving unit, 14" D x 36" W x 44.5" H |
| 1 | N4-RS72-3 | Steel shelving unit, 14" D x 72" W x 44.5" H |
| 2 | X50-B | 2 Drawer Cabinet |

The Deluxe package is designed to fit in a Metris with a single sliding door.



MERCEDES-BENZ METRIS

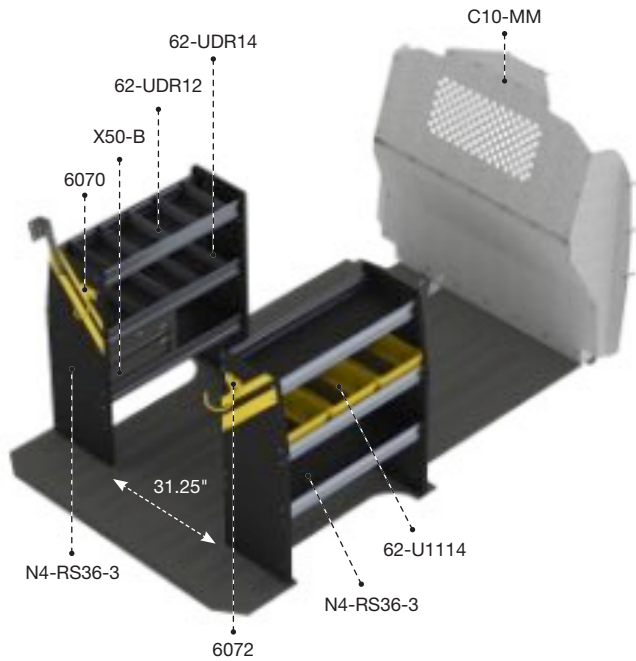

MMR-16 SERVICE

| | | | | | |
|--|---------|--|------------|--|----------|
| | Steel | | 126", 135" | | Standard |
| | 203 lbs | | 3.7 hrs | | Yes |

| Qty | Part # | Description |
|-----|-----------|--------------------------------------------------|
| 1 | 6070 | 6" Hook, 3" opening, painted |
| 1 | 6072 | 8" Swivel hook, 4" opening, painted |
| 3 | 62-U1114 | 14" Deep plastic bin |
| 1 | 62-UDR12 | Set of 5 dividers for a 12" shelf |
| 1 | 62-UDR14 | Set of 5 dividers for a 14" shelf |
| 1 | C10-MM | Contoured steel partition with perforated window |
| 2 | N4-RS36-3 | Steel shelving units, 14" D x 36" W x 44.5" H |
| 1 | X50-B | Compact 2-drawer unit |

The Base package is designed to fit in a Metris with dual sliding doors.

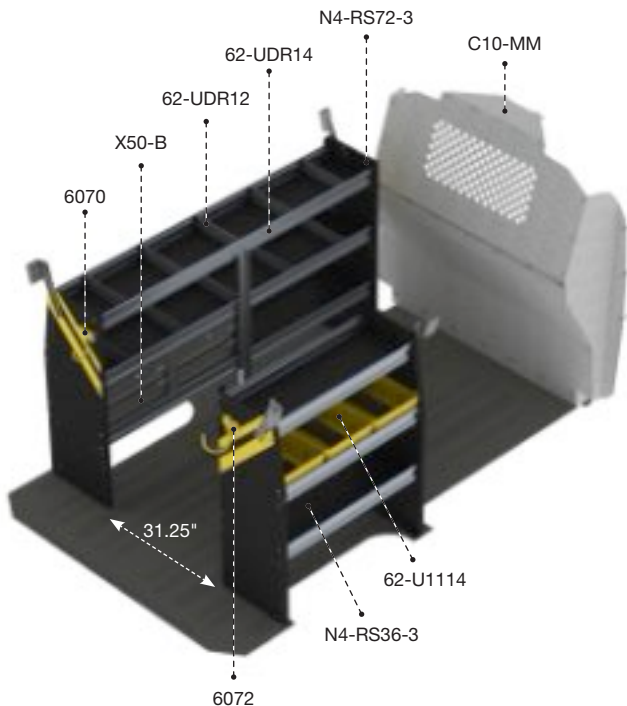

MML-16 SERVICE

| | | | | | |
|--|---------|--|------------|--|----------|
| | Steel | | 126", 135" | | Standard |
| | 254 lbs | | 4.1 hrs | | Yes |

| Qty | Part # | Description |
|-----|-----------|--------------------------------------------------|
| 1 | 6070 | 6" Hook, 3" opening, painted |
| 1 | 6072 | 8" Swivel hook, 4" opening, painted |
| 3 | 62-U1114 | 14" Deep plastic bin |
| 1 | 62-UDR12 | Set of 5 dividers for a 12" shelf |
| 1 | 62-UDR14 | Set of 5 dividers for a 14" shelf |
| 1 | C10-MM | Contoured steel partition with perforated window |
| 1 | N4-RS36-3 | Steel shelving unit, 14" D x 36" W x 44.5" H |
| 1 | N4-RS72-3 | Steel shelving unit, 14" D x 72" W x 44.5" H |
| 2 | X50-B | Compact 2-drawer unit |

The Deluxe package is designed to fit in a Metris with a single sliding door.

MERCEDES-BENZ METRIS



PACKAGES

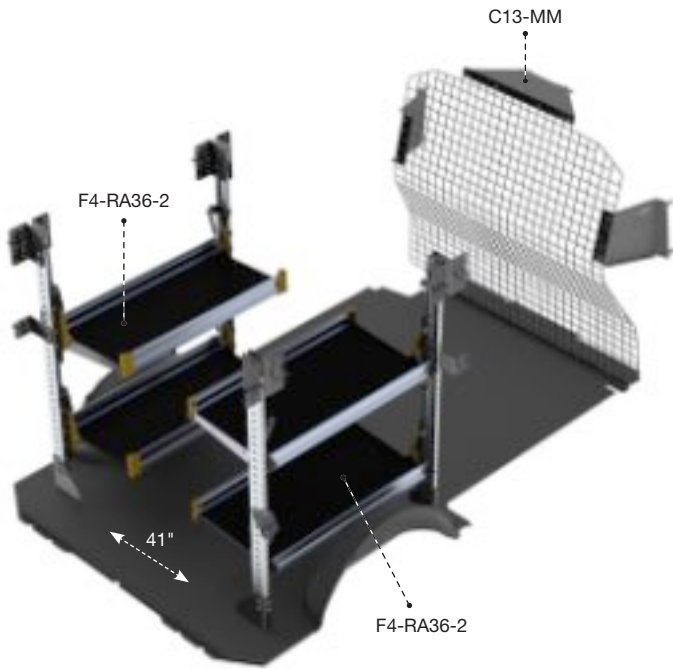

MMR-19

DELIVERY

| | | |
|----------|------------|----------|
| Aluminum | 126", 135" | Standard |
| 159 lbs | 4.4 hrs | Yes |

| Qty | Part # | Description |
|-----|------------------|-------------------------------------------------|
| 1 | C13-MM | Wire mesh partition |
| 2 | F4-RA36-2 | Fold-away unit, 2 levels, 22" D x 36" W x 47" H |

The Base package is designed to fit in a Metris with dual sliding doors.

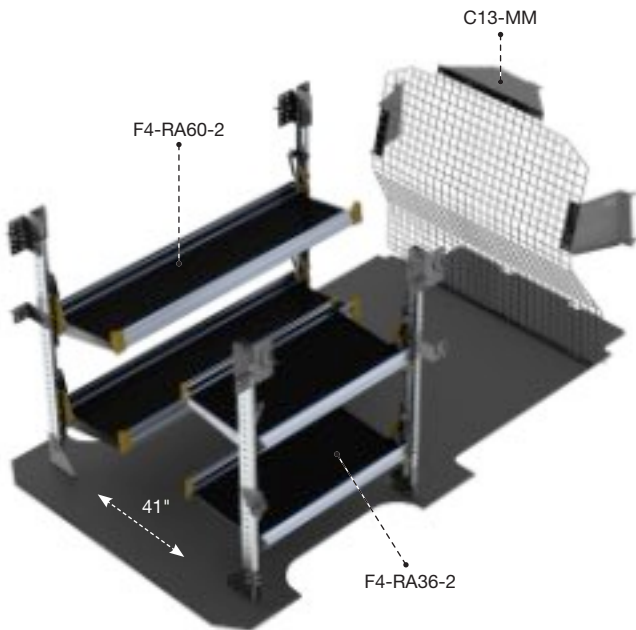

MML-19

DELIVERY

| | | |
|----------|------------|----------|
| Aluminum | 126", 135" | Standard |
| 171 lbs | 4.4 hrs | Yes |

| Qty | Part # | Description |
|-----|------------------|-------------------------------------------------|
| 1 | C13-MM | Wire mesh partition |
| 1 | F4-RA60-2 | Fold-away unit, 2 levels, 22" D x 60" W x 47" H |
| 1 | F4-RA36-2 | Fold-away unit, 2 levels, 22" D x 36" W x 47" H |

The Deluxe package is designed to fit in a Metris with a single sliding door.



ALUMINUM **MML-27**

MERCEDES-BENZ **METRIS**



MERCEDES-BENZ METRIS



PACKAGES

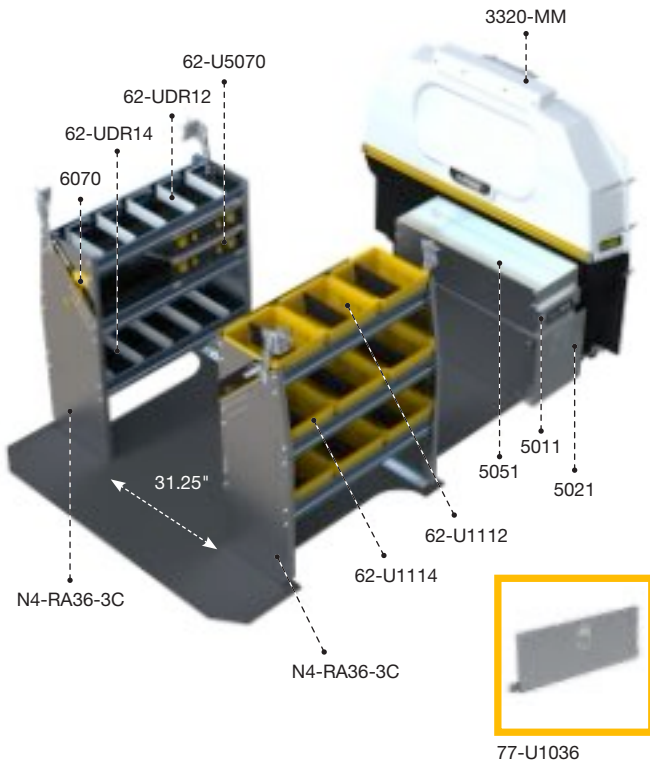

MMR-27 ALUMINUM

| | | |
|----------|------------|----------|
| Aluminum | 126", 135" | Standard |
| 253 lbs | 6.2 hrs | Yes |

| Qty | Part # | Description |
|-----|------------|---------------------------------------------------------------|
| 1 | 3320-MM | Max view contoured safety partition |
| 1 | 5011 | Partslider 36" D |
| 1 | 5021 | Tool drawer 36" D x 14" W x 16" H |
| 1 | 5051 | Top edge |
| 2 | 62-U5070 | Partskeeper carry case with holder |
| 1 | 6070 | 6" Hook, 3" opening, painted |
| 3 | 62-U1112 | 14" Deep plastic bin |
| 6 | 62-U1114 | 14" Deep plastic bin |
| 1 | 62-UDR12 | Set of 5 dividers for a 12" shelf |
| 1 | 62-UDR14 | Set of 5 dividers for a 14" shelf |
| 1 | 77-U1036 | Adjustable shelving door unit - 33" W - for 36" & 72" shelves |
| 2 | N4-RA36-3C | Composite Aluminum shelving units, 14" D x 36" W x 44.5" H |

The Base package is designed to fit in a Metris with dual sliding doors.

MML-27 ALUMINUM

| | | |
|----------|------------|----------|
| Aluminum | 126", 135" | Standard |
| 270 lbs | 6.3 hrs | Yes |

| Qty | Part # | Description |
|-----|------------|---------------------------------------------------------------|
| 1 | 3320-MM | Max view contoured safety partition |
| 1 | 5011 | Partslider 36" D |
| 1 | 5021 | Tool drawer 36" D x 14" W x 16" H |
| 1 | 5051 | Top edge |
| 2 | 62-U5070 | Partskeeper carry case with holder |
| 1 | 6070 | 6" Hook, 3" opening, painted |
| 3 | 62-U1112 | 12" Deep plastic bin |
| 6 | 62-U1114 | 14" Deep plastic bin |
| 1 | 62-UDR12 | Set of 5 dividers for a 12" shelf |
| 1 | 62-UDR14 | Set of 5 dividers for a 14" shelf |
| 1 | 77-U1036 | Adjustable shelving door unit - 33" W - for 36" & 72" shelves |
| 1 | N4-RA36-3C | Composite Aluminum shelving unit, 14" D x 36" W x 44.5" H |
| 1 | N4-RA72-3C | Composite Aluminum shelving unit, 14" D x 72" W x 44.5" H |

The Deluxe package is designed to fit in a Metris with a single sliding door.

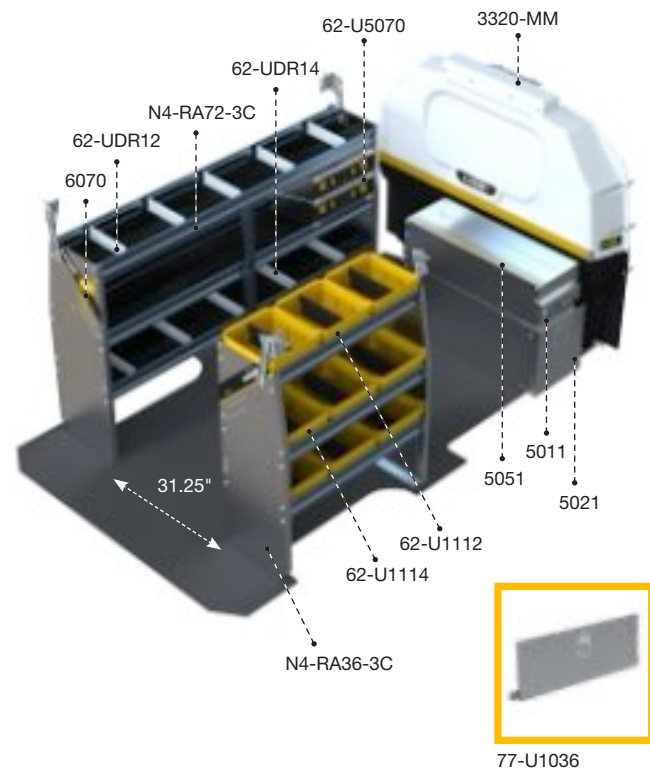



MERCEDES-BENZ **SPRINTER**

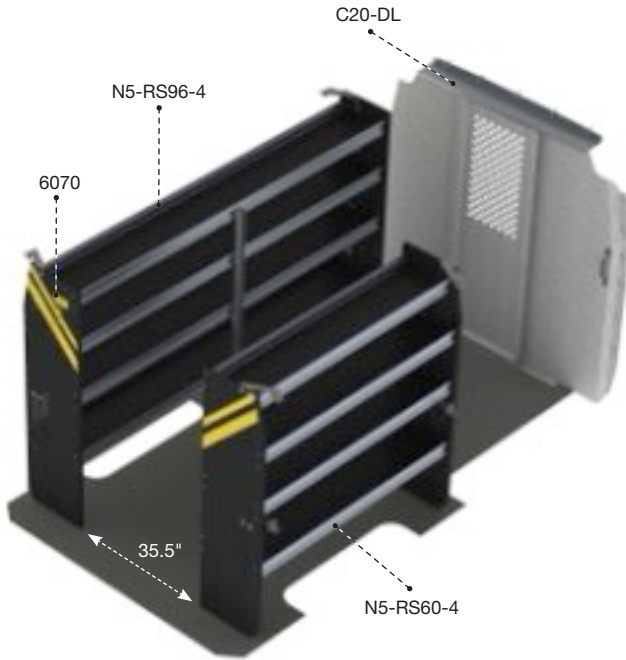

DLS-10
CONTRACTOR

| | | |
|---------|---------|----------|
| Steel | 144" | Low Roof |
| 291 lbs | 3.8 hrs | Yes |

| Qty | Part # | Description |
|-----|-----------|------------------------------------------------------|
| 1 | 6070 | 6" Hook, 3" opening, painted |
| 1 | C20-DL | Straight partition with perforated window, no access |
| 1 | N5-RS60-4 | Steel shelving unit, 14" D x 60" W x 62" H |
| 1 | N5-RS96-4 | Steel shelving unit, 14" D x 96" W x 62" H |

PACKAGES

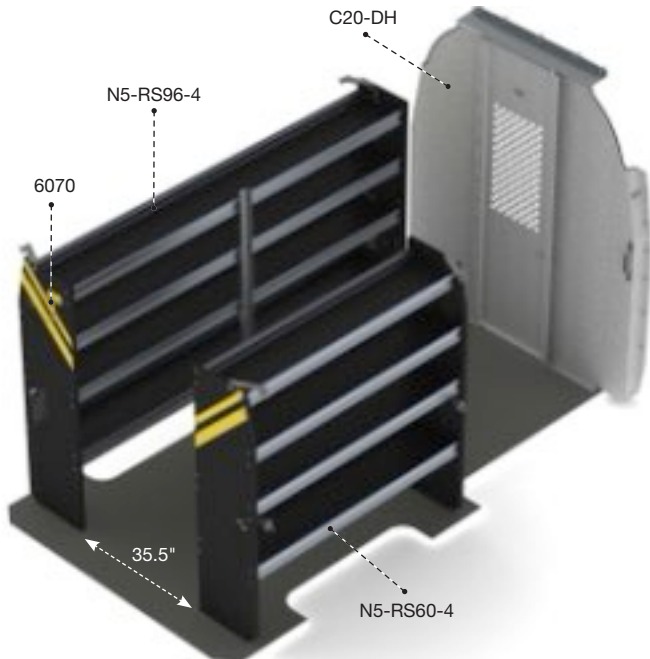

DHS-10
CONTRACTOR

| | | |
|---------|---------|-----------|
| Steel | 144" | High Roof |
| 300 lbs | 3.8 hrs | Yes |

| Qty | Part # | Description |
|-----|-----------|------------------------------------------------------|
| 1 | 6070 | 6" Hook, 3" opening, painted |
| 1 | C20-DH | Straight partition with perforated window, no access |
| 1 | N5-RS60-4 | Steel shelving unit, 14" D x 60" W x 62" H |
| 1 | N5-RS96-4 | Steel shelving unit, 14" D x 96" W x 62" H |



ELECTRICAL
DHS-11

MERCEDES-BENZ **SPRINTER**





MERCEDES-BENZ SPRINTER

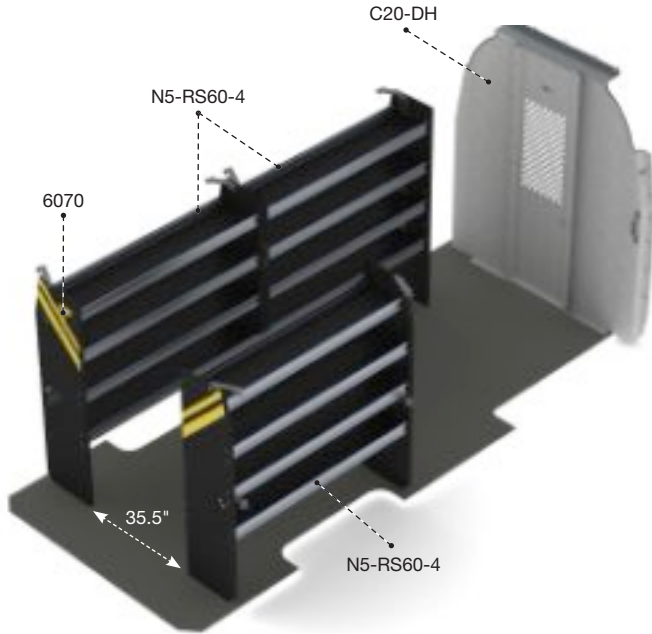

DHL-10 CONTRACTOR

| | | |
|---------|-----------------|-----------|
| Steel | 170", 170" Ext. | High Roof |
| 355 lbs | 4.8 hrs | Yes |

| Qty | Part # | Description |
|-----|-----------|------------------------------------------------------|
| 1 | 6070 | 6" Hook, 3" opening, painted |
| 1 | C20-DH | Straight partition with perforated window, no access |
| 3 | N5-RS60-4 | Steel shelving unit, 14" D x 60" W x 62" H |

PACKAGES

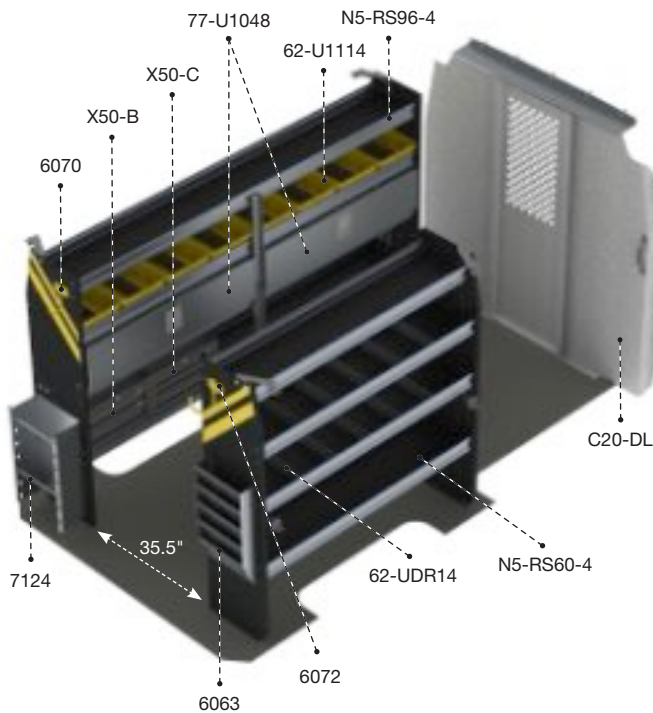

DLS-11 ELECTRICAL

| | | |
|---------|---------|----------|
| Steel | 144" | Low Roof |
| 404 lbs | 6.3 hrs | Yes |

| Qty | Part # | Description |
|-----|-----------|---------------------------------------------------------------|
| 1 | 6063 | Paper holder, extra deep, 5 slots |
| 1 | 6070 | 6" Hook, 3" opening, painted |
| 1 | 6072 | 8" Swivel hook, 4" opening, painted |
| 8 | 62-U1114 | 14" Deep plastic bin |
| 2 | 62-UDR14 | Set of 5 dividers for a 14" shelf |
| 1 | 7124 | Reel holder with two 5/8" diameter rods |
| 2 | 77-U1048 | Adjustable shelving door unit - 45" W - for 48" & 96" shelves |
| 1 | C20-DL | Straight partition with perforated window, no access |
| 1 | N5-RS60-4 | Steel shelving unit, 14" D x 60" W x 62" H |
| 1 | N5-RS96-4 | Steel shelving unit, 14" D x 96" W x 62" H |
| 1 | X50-B | Compact 2-drawer unit |
| 1 | X50-C | Compact 3-drawer unit |

MERCEDES-BENZ SPRINTER



PACKAGES

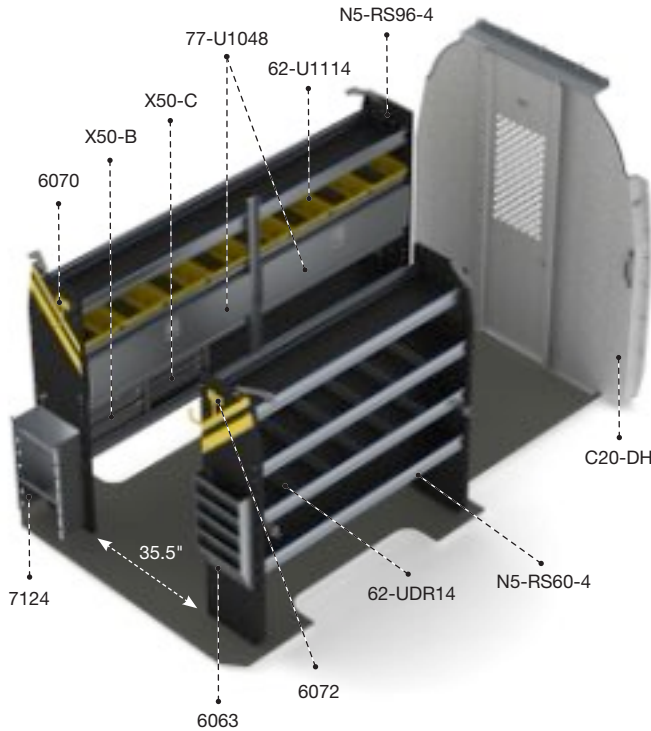

DHS-11 ELECTRICAL

| | | | | | |
|--|---------|--|---------|--|-----------|
| | Steel | | 144" | | High Roof |
| | 413 lbs | | 6.3 hrs | | Yes |

| Qty | Part # | Description |
|-----|-----------|---------------------------------------------------------------|
| 1 | 6063 | Paper holder, extra deep, 5 slots |
| 1 | 6070 | 6" Hook, 3" opening, painted |
| 1 | 6072 | 8" Swivel hook, 4" opening, painted |
| 8 | 62-U1114 | 14" Deep plastic bin |
| 2 | 62-UDR14 | Set of 5 dividers for a 14" shelf |
| 1 | 7124 | Reel holder with two 5/8" diameter rods |
| 2 | 77-U1048 | Adjustable shelving door unit - 45" W - for 48" & 96" shelves |
| 1 | C20-DH | Straight partition with perforated window, no access |
| 1 | N5-RS60-4 | Steel shelving unit, 14" D x 60" W x 62" H |
| 1 | N5-RS96-4 | Steel shelving unit, 14" D x 96" W x 62" H |
| 1 | X50-B | Compact 2-drawer unit |
| 1 | X50-C | Compact 3-drawer unit |

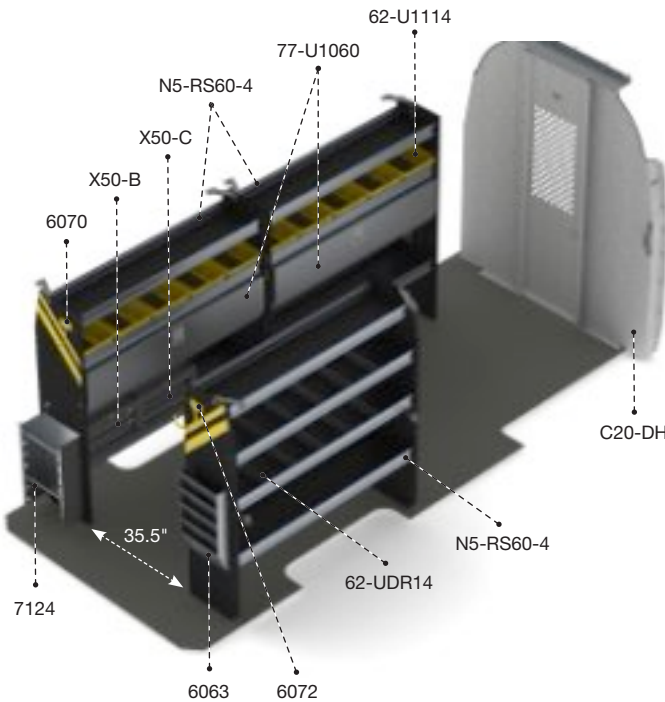

DHL-11 ELECTRICAL

| | | | | | |
|--|---------|--|-----------------|--|-----------|
| | Steel | | 170", 170" Ext. | | High Roof |
| | 475 lbs | | 7.3 hrs | | Yes |

| Qty | Part # | Description |
|-----|-----------|---------------------------------------------------------|
| 1 | 6063 | Paper holder, extra deep, 5 slots |
| 1 | 6070 | 6" Hook, 3" opening, painted |
| 1 | 6072 | 8" Swivel hook, 4" opening, painted |
| 10 | 62-U1114 | 14" Deep plastic bin |
| 2 | 62-UDR14 | Set of 5 dividers for a 14" shelf |
| 1 | 7124 | Reel holder with two 5/8" diameter rods |
| 2 | 77-U1060 | Adjustable shelving door unit - 57" W - for 60" shelves |
| 1 | C20-DH | Straight partition with perforated window, no access |
| 3 | N5-RS60-4 | Steel shelving units, 14" D x 60" W x 62" H |
| 1 | X50-B | Compact 2-drawer unit |
| 1 | X50-C | Compact 3-drawer unit |



MERCEDES-BENZ **SPRINTER**

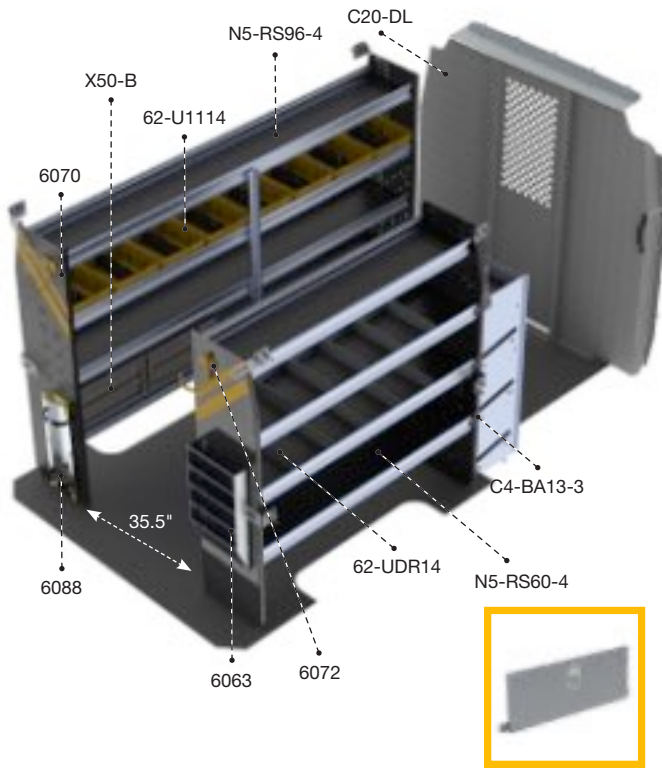

DLS-12

HVAC

| | | |
|---------|---------|----------|
| Steel | 144" | Low Roof |
| 414 lbs | 6.1 hrs | Yes |

| Qty | Part # | Description |
|-----|------------------|-----------------------------------------------------------|
| 1 | C4-BA13-3 | 3 Tier refrigerant rack for large bottles |
| 1 | 6063 | Paper holder, extra deep, 5 slots |
| 1 | 6070 | 6" Hook, 3" opening, painted |
| 1 | 6072 | 8" Swivel hook, 4" opening, painted |
| 1 | 6088 | Large aluminum bottle holder, with two black nylon straps |
| 8 | 62-U1114 | 14" Deep plastic bin |
| 2 | 62-UDR14 | Set of 5 dividers for a 14" shelf |
| 1 | 77-U1060 | Adjustable shelving door unit - 57" W - for 60" shelves |
| 1 | C20-DL | Straight partition with perforated window, no access |
| 1 | N5-RS60-4 | Steel shelving unit, 14" D x 60" W x 62" H |
| 1 | N5-RS96-4 | Steel shelving unit, 14" D x 96" W x 62" H |
| 2 | X50-B | Compact 2-drawer unit |

77-U1060

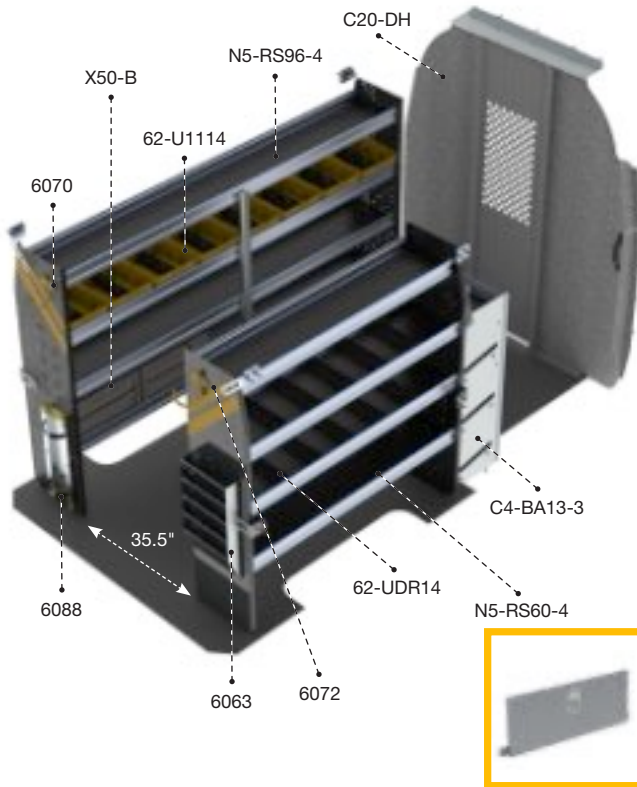

DHS-12

HVAC

| | | |
|---------|---------|-----------|
| Steel | 144" | High Roof |
| 423 lbs | 6.1 hrs | Yes |

| Qty | Part # | Description |
|-----|------------------|-----------------------------------------------------------|
| 1 | C4-BA13-3 | 3 Tier refrigerant rack for large bottles |
| 1 | 6063 | Paper holder, extra deep, 5 slots |
| 1 | 6070 | 6" Hook, 3" opening, painted |
| 1 | 6072 | 8" Swivel hook, 4" opening, painted |
| 1 | 6088 | Large aluminum bottle holder, with two black nylon straps |
| 8 | 62-U1114 | 14" Deep plastic bin |
| 2 | 62-UDR14 | Set of 5 dividers for a 14" shelf |
| 1 | 77-U1060 | Adjustable shelving door unit - 57" W - for 60" shelves |
| 1 | C20-DH | Straight partition with perforated window, no access |
| 1 | N5-RS60-4 | Steel shelving unit, 14" D x 60" W x 62" H |
| 1 | N5-RS96-4 | Steel shelving unit, 14" D x 96" W x 62" H |
| 2 | X50-B | Compact 2-drawer unit |

77-U1060

MERCEDES-BENZ SPRINTER



PACKAGES

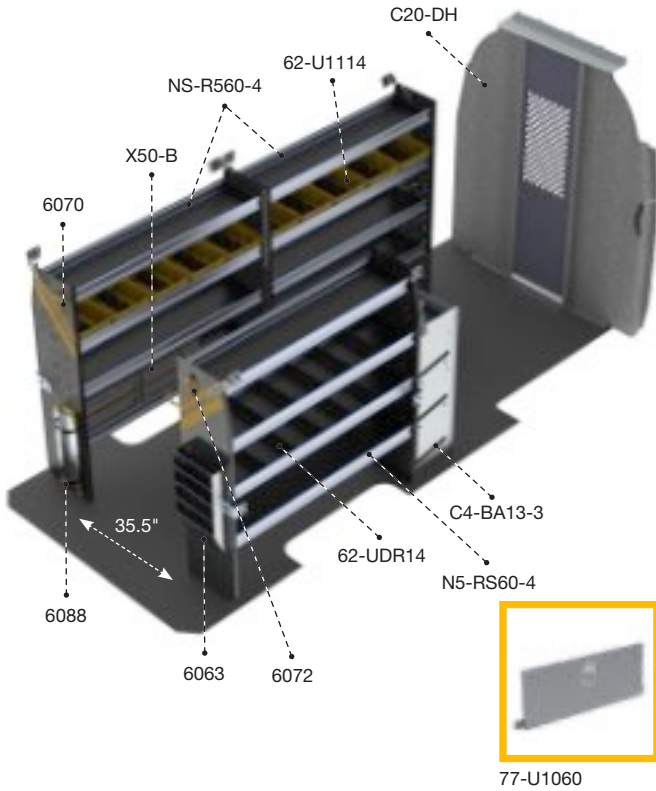

DHL-12 HVAC

| | | |
|---------|-----------------|-----------|
| Steel | 170", 170" Ext. | High Roof |
| 482 lbs | 7.1 hrs | Yes |

| Qty | Part # | Description |
|-----|------------------|-----------------------------------------------------------|
| 1 | C4-BA13-3 | 3 Tier refrigerant rack for large bottles |
| 1 | 6063 | Paper holder, extra deep, 5 slots |
| 1 | 6070 | 6" Hook, 3" opening, painted |
| 1 | 6072 | 8" Swivel hook, 4" opening, painted |
| 1 | 6088 | Large aluminum bottle holder, with two black nylon straps |
| 10 | 62-U1114 | 14" Deep plastic bin |
| 2 | 62-UDR14 | Set of 5 dividers for a 14" shelf |
| 1 | 77-U1060 | Adjustable shelving door unit - 57" W - for 60" shelves |
| 1 | C20-DH | Straight partition with perforated window, no access |
| 3 | N5-RS60-4 | Steel shelving units, 14" D x 60" W x 62" H |
| 2 | X50-B | Compact 2-drawer unit |

DLS-16 SERVICE

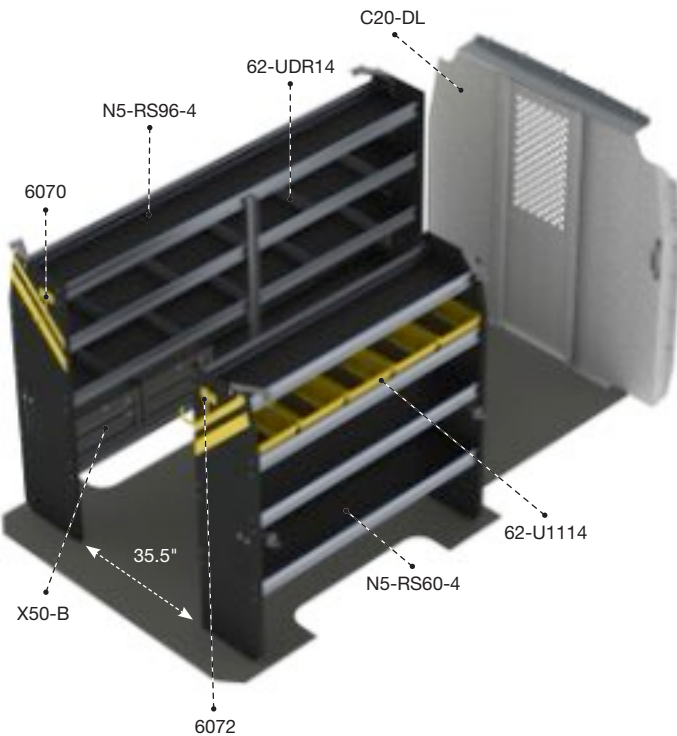

| | | |
|---------|---------|----------|
| Steel | 144" | Low Roof |
| 361 lbs | 4.6 hrs | Yes |

| Qty | Part # | Description |
|-----|------------------|------------------------------------------------------|
| 1 | 6070 | 6" Hook, 3" opening, painted |
| 1 | 6072 | 8" Swivel hook, 4" opening, painted |
| 5 | 62-U1114 | 14" Deep plastic bin |
| 2 | 62-UDR14 | Set of 5 dividers for a 14" shelf |
| 1 | C20-DL | Straight partition with perforated window, no access |
| 1 | N5-RS60-4 | Steel shelving unit, 14" D x 60" W x 62" H |
| 1 | N5-RS96-4 | Steel shelving unit, 14" D x 96" W x 62" H |
| 2 | X50-B | Compact 2-drawer unit |



MERCEDES-BENZ **SPRINTER**

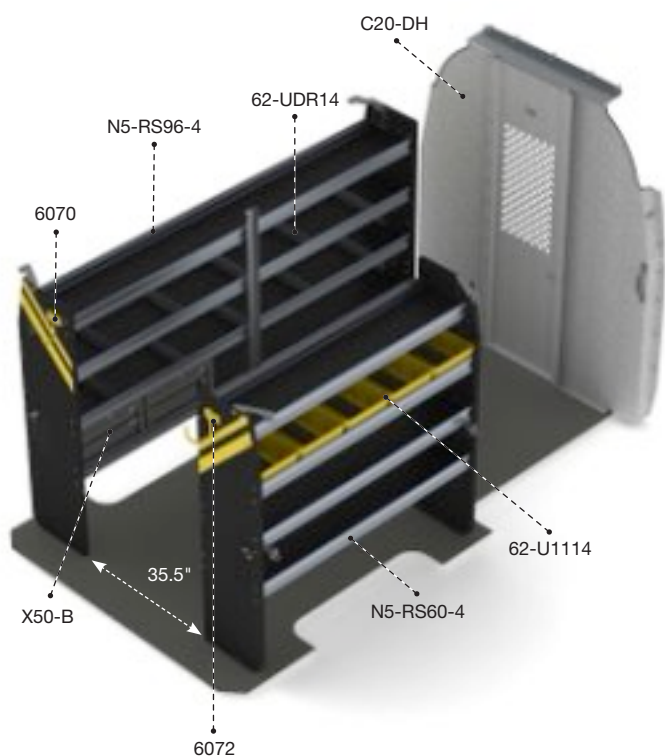

DHS-16
SERVICE

| | | |
|---------|---------|-----------|
| Steel | 144" | High Roof |
| 370 lbs | 4.6 hrs | Yes |

| Qty | Part # | Description |
|-----|-----------|------------------------------------------------------|
| 1 | 6070 | 6" Hook, 3" opening, painted |
| 1 | 6072 | 8" Swivel hook, 4" opening, painted |
| 5 | 62-U1114 | 14" Deep plastic bin |
| 2 | 62-UDR14 | Set of 5 dividers for a 14" shelf |
| 1 | C20-DH | Straight partition with perforated window, no access |
| 1 | N5-RS60-4 | Steel shelving unit, 14" D x 60" W x 62" H |
| 1 | N5-RS96-4 | Steel shelving unit, 14" D x 96" W x 62" H |
| 2 | X50-B | Compact 2-drawer unit |

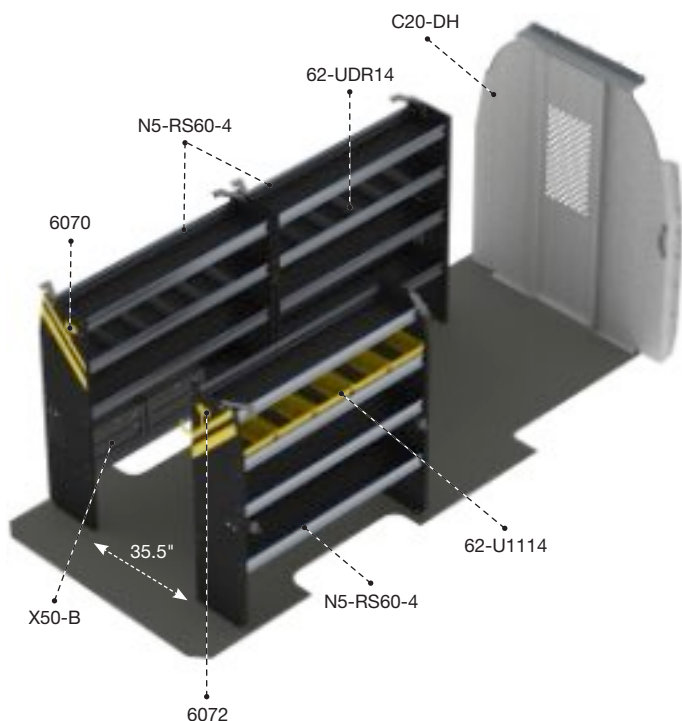

DHL-16
SERVICE

| | | |
|---------|-----------------|-----------|
| Steel | 170", 170" Ext. | High Roof |
| 425 lbs | 5.6 hrs | Yes |

| Qty | Part # | Description |
|-----|-----------|------------------------------------------------------|
| 1 | 6070 | 6" Hook, 3" opening, painted |
| 1 | 6072 | 8" Swivel hook, 4" opening, painted |
| 5 | 62-U1114 | 14" Deep plastic bin |
| 2 | 62-UDR14 | Set of 5 dividers for a 14" shelf |
| 1 | C20-DH | Straight partition with perforated window, no access |
| 3 | N5-RS60-4 | Steel shelving units, 14" D x 60" W x 62" H |
| 2 | X50-B | Compact 2-drawer unit |

MERCEDES-BENZ **SPRINTER**



PACKAGES

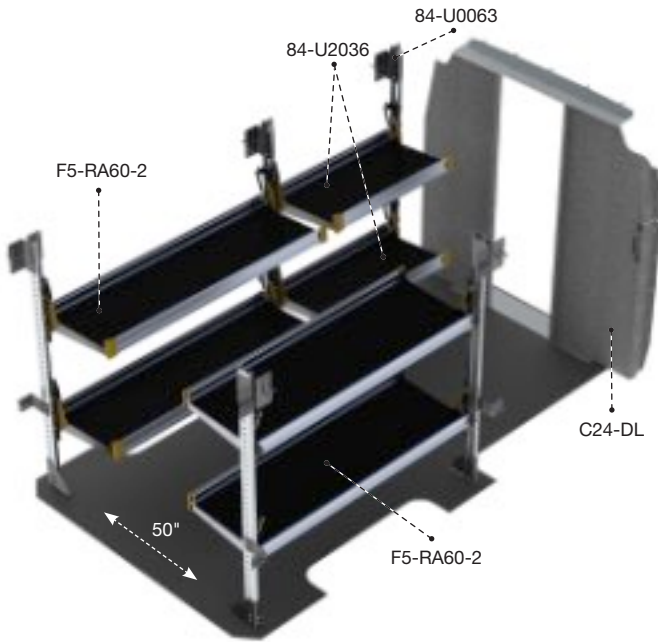

DLS-19 DELIVERY

| | | |
|----------|---------|----------|
| Aluminum | 144" | Low Roof |
| 274 lbs | 5.3 hrs | Yes |

| Qty | Part # | Description |
|-----|------------------|-------------------------------------------------|
| 1 | 84-U0063 | Post assembly for fold-away shelving, 63" |
| 2 | 84-U2036 | Fold-away shelf tray, 20" D x 36" W |
| 1 | C24-DL | Straight walk through steel partition |
| 2 | F5-RA60-2 | Fold-away unit, 2 levels, 25" D x 60" W x 63" H |

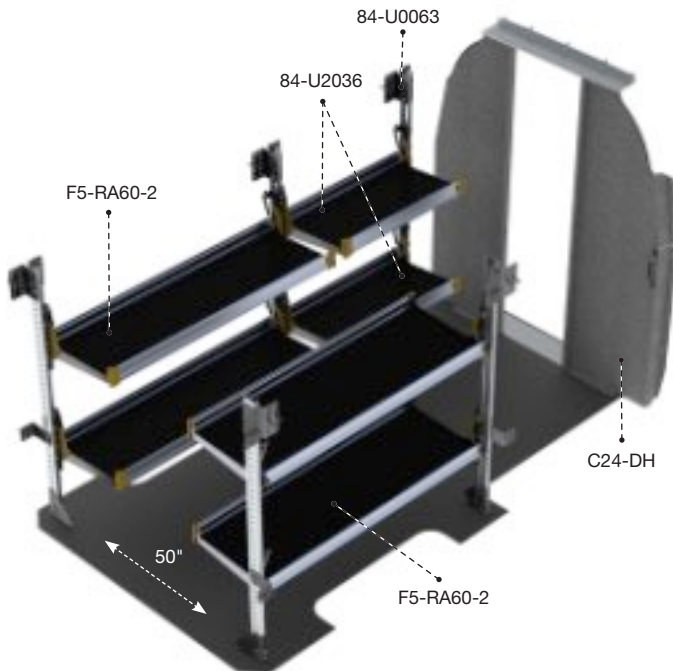

DHS-19 DELIVERY

| | | |
|----------|---------|-----------|
| Aluminum | 144" | High Roof |
| 277 lbs | 5.3 hrs | Yes |

| Qty | Part # | Description |
|-----|------------------|-------------------------------------------------|
| 1 | 84-U0063 | Post assembly for fold-away shelving, 63" |
| 2 | 84-U2036 | Fold-away shelf tray, 20" D x 36" W |
| 1 | C24-DH | Straight walk through steel partition |
| 2 | F5-RA60-2 | Fold-away unit, 2 levels, 25" D x 60" W x 63" H |



MERCEDES-BENZ **SPRINTER**

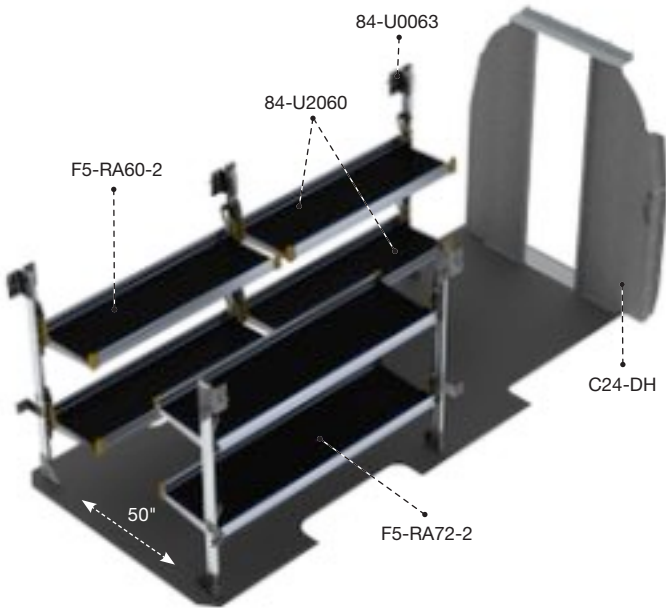

DHL-19
DELIVERY

| | | |
|----------|-----------------|-----------|
| Aluminum | 170", 170" Ext. | High Roof |
| 299 | 5.3 hrs | Yes |

| Qty | Part # | Description |
|-----|------------------|-------------------------------------------|
| 1 | C24-DH | Straight walk through steel partition |
| 1 | F5-RA60-2 | Fold-away unit, 2 levels, 60" W x 63" H |
| 1 | 84-U0063 | Post assembly for fold-away shelving, 63" |
| 2 | 84-U2060 | Fold-away shelf tray, 20" D x 60" W |
| 1 | F5-RA72-2 | Fold-away unit, 2 levels, 72" W x 63" H |

PACKAGES

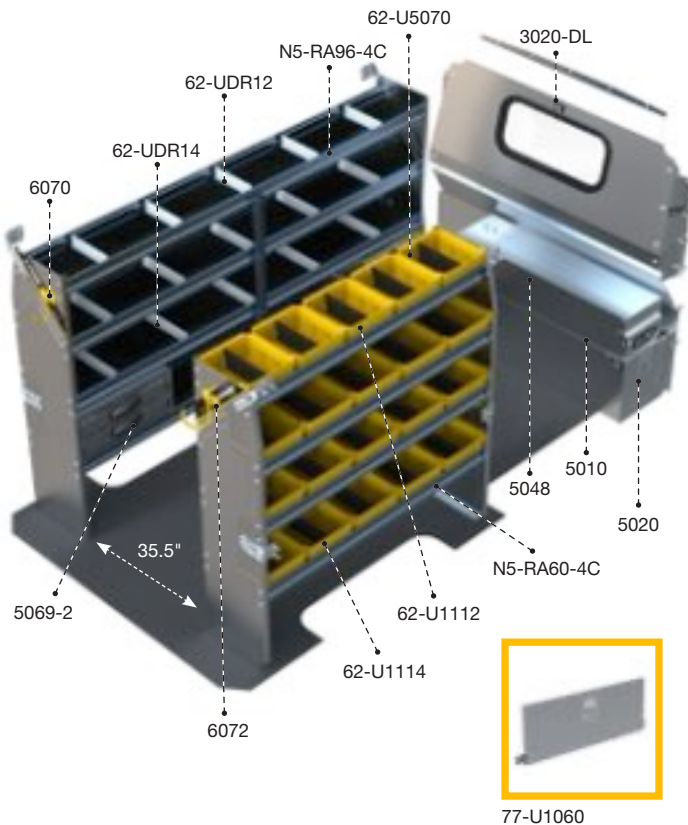

DLS-27
ALUMINUM

| | | |
|----------|---------|----------|
| Aluminum | 144" | Low Roof |
| 404 lbs | 7.5 hrs | Yes |

| Qty | Part # | Description |
|-----|-------------------|------------------------------------------------------------|
| 1 | 3020-DL | Countoured safety partition with glass window |
| 1 | 5010 | Partslider drawer |
| 1 | 5020 | Tool drawer 48" D x 14" W x 16" H |
| 1 | 5048 | Top edge |
| 1 | 5069-2 | 2 Drawer cabinet |
| 2 | 62-U5070 | Partskeeper carry case with holder |
| 1 | 6070 | 6" Hook, 3" opening, painted |
| 1 | 6072 | 8" Swivel hook, 4" opening, painted |
| 5 | 62-U1112 | 12" Deep plastic bin |
| 15 | 62-U1114 | 14" Deep plastic bin |
| 1 | 62-UDR12 | Set of 5 dividers for a 12" shelf |
| 2 | 62-UDR14 | Set of 5 dividers for a 14" shelf |
| 1 | 77-U1060 | Adjustable shelving door unit - 57" W - for 60" shelves |
| 1 | N5-RA60-4C | Composite Aluminum shelving unit, 60", 14"D x 60" W x 62"H |
| 1 | N5-RA96-4C | Composite Aluminum shelving unit, 96", 14"D x 96" W x 62"H |

MERCEDES-BENZ SPRINTER



PACKAGES

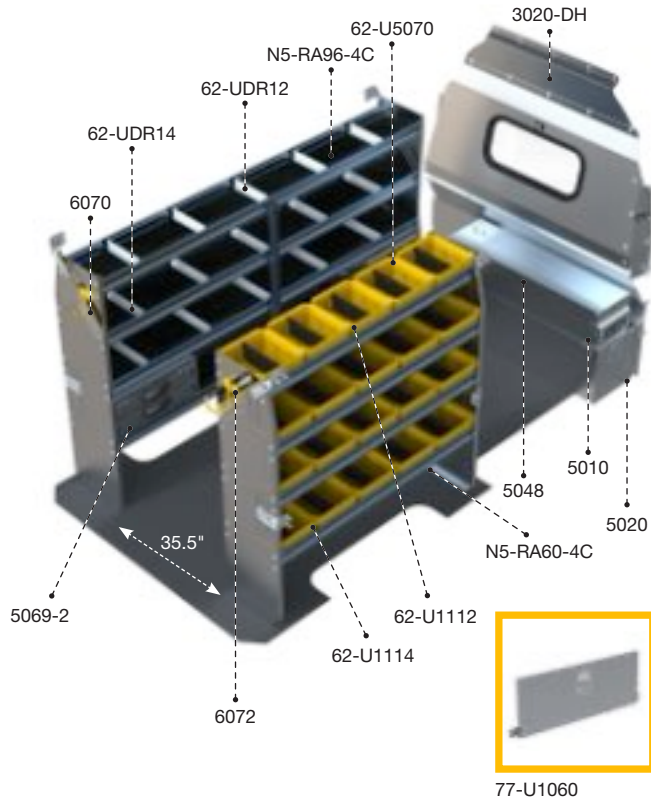

DHS-27 ALUMINUM

| | | |
|----------|---------|-----------|
| Aluminum | 144" | High Roof |
| 411 lbs | 7.5 hrs | Yes |

| Qty | Part # | Description |
|-----|-------------------|------------------------------------------------------------|
| 1 | 3020-DH | Countoured safety partition with glass window |
| 1 | 5010 | Partslider drawer |
| 1 | 5020 | Tool drawer 48" D x 14" W x 16" H |
| 1 | 5048 | Top edge |
| 1 | 5069-2 | 2 Drawer cabinet |
| 2 | 62-U5070 | Partskeeper carry case with holder |
| 1 | 6070 | 6" Hook, 3" opening, painted |
| 1 | 6072 | 8" Swivel hook, 4" opening, painted |
| 5 | 62-U1112 | 12" Deep plastic bin |
| 15 | 62-U1114 | 14" Deep plastic bin |
| 1 | 62-UDR12 | Set of 5 dividers for a 12" shelf |
| 2 | 62-UDR14 | Set of 5 dividers for a 14" shelf |
| 1 | 77-U1060 | Adjustable shelving door unit - 57" W - for 60" shelves |
| 1 | N5-RA60-4C | Composite Aluminum shelving unit, 60", 14"D x 60" W x 62"H |
| 1 | N5-RA96-4C | Composite Aluminum shelving unit, 96", 14"D x 96" W x 62"H |

DHL-27 ALUMINUM

| | | |
|----------|-----------------|-----------|
| Aluminum | 170", 170" Ext. | High Roof |
| 445 lbs | 8.5 hrs | Yes |

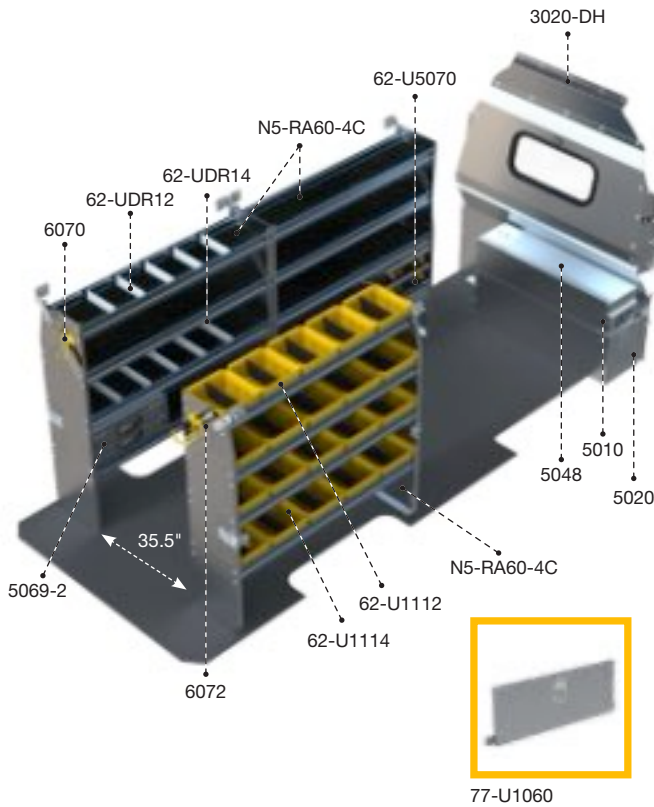

| Qty | Part # | Description |
|-----|-------------------|-------------------------------------------------------------|
| 1 | 3020-DH | Countoured safety partition with glass window |
| 1 | 5010 | Partslider 48" D |
| 1 | 5020 | Tool drawer 48" D x 14" W x 16" H |
| 1 | 5048 | Top edge |
| 1 | 5069-2 | 2 Drawer cabinet |
| 2 | 62-U5070 | Partskeeper carry case with holder |
| 1 | 6070 | 6" Hook, 3" opening, painted |
| 1 | 6072 | 8" Swivel hook, 4" opening, painted |
| 5 | 62-U1112 | 12" Deep plastic bin |
| 15 | 62-U1114 | 14" Deep plastic bin |
| 1 | 62-UDR12 | Set of 5 dividers for a 12" shelf |
| 2 | 62-UDR14 | Set of 5 dividers for a 14" shelf |
| 1 | 77-U1060 | Adjustable shelving door unit - 57" W - for 60" shelves |
| 3 | N5-RA60-4C | Composite Aluminum shelving units, 60", 14"D x 60" W x 62"H |



ALUMINUM **DHS-27**

MERCEDES-BENZ **SPRINTER**





RAM PROMASTER

PACKAGES

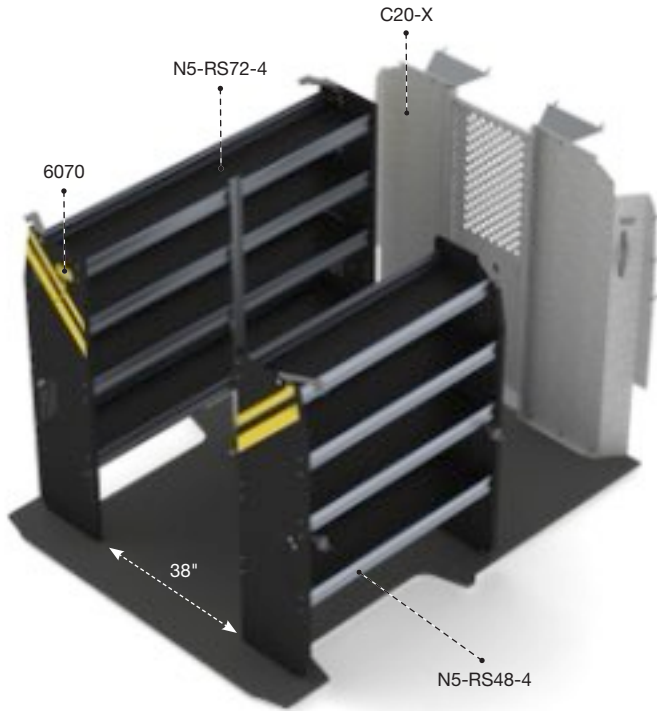

RPS-10 CONTRACTOR

| | | |
|---------|------------|------------|
| Steel | 118", 136" | Low / High |
| 259 lbs | 3.8 hrs | Yes |

| Qty | Part # | Description |
|-----|-----------|------------------------------------------------------------|
| 1 | 6070 | 6" Hook, 3" opening, painted |
| 1 | C20-X | Straight steel partition with perforated window, no access |
| 1 | N5-RS48-4 | Steel shelving unit, 14" D x 48" W x 62" H |
| 1 | N5-RS72-4 | Steel shelving unit, 14" D x 72" W x 62" H |

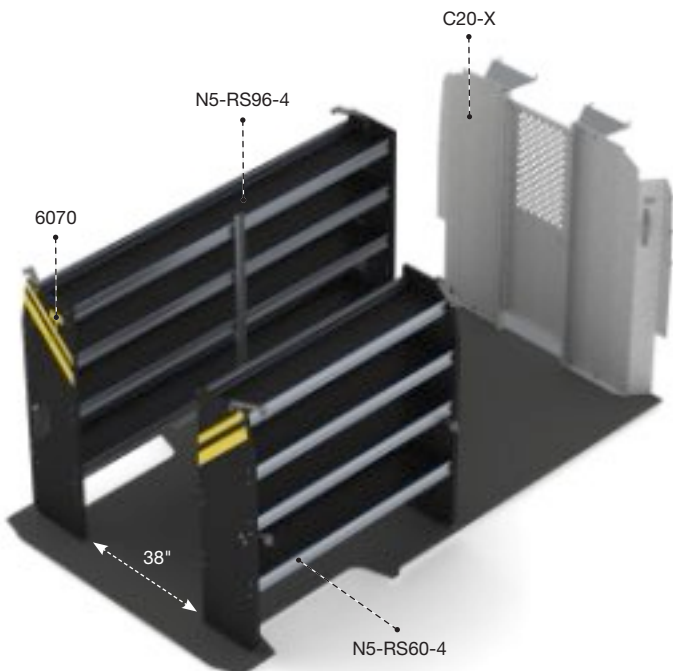

RPL-10 CONTRACTOR

| | | |
|---------|-----------------|------|
| Steel | 159", 159" Ext. | High |
| 289 lbs | 3.8 hrs | Yes |

| Qty | Part # | Description |
|-----|-----------|------------------------------------------------------------|
| 1 | 6070 | 6" Hook, 3" opening, painted |
| 1 | C20-X | Straight steel partition with perforated window, no access |
| 1 | N5-RS60-4 | Steel shelving unit, 14" D x 60" W x 62" H |
| 1 | N5-RS96-4 | Steel shelving unit, 14" D x 96" W x 62" H |



RAM PROMASTER

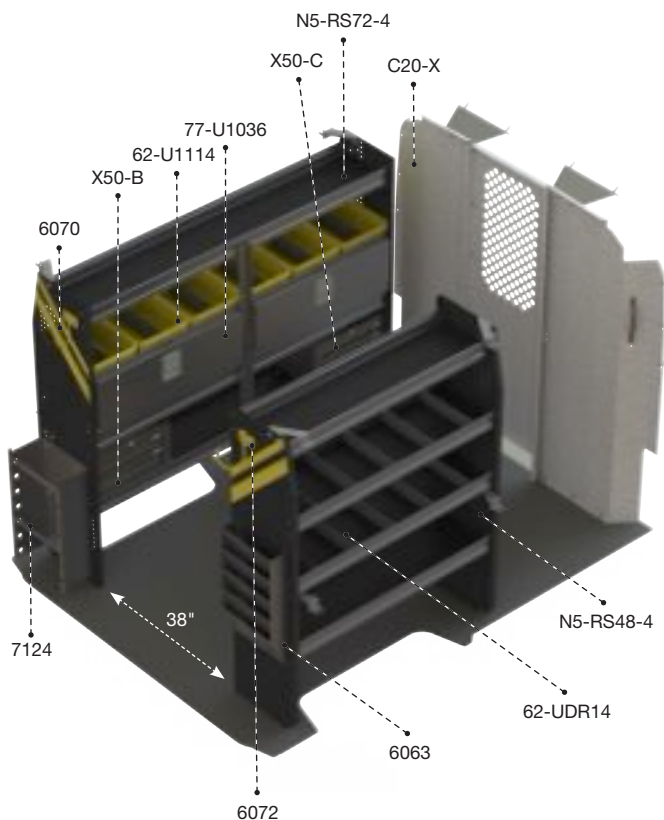

RPS-11 ELECTRICAL

| | | |
|---------|------------|------------|
| Steel | 118", 136" | Low / High |
| 364 lbs | 6.3 hrs | Yes |

| Qty | Part # | Description |
|-----|-----------|---------------------------------------------------------------|
| 1 | 6063 | Paper holder, extra deep, 5 slots |
| 1 | 6070 | 6" Hook, 3" opening, painted |
| 1 | 6072 | 8" Swivel hook, 4" opening, painted |
| 6 | 62-U1114 | 14" Deep plastic bin |
| 2 | 62-UDR14 | Set of 5 dividers for a 14" shelf |
| 1 | 7124 | Reel holder with two 5/8" diameter rods |
| 2 | 77-U1036 | Adjustable shelving door unit - 33" W - for 36" & 72" shelves |
| 1 | C20-X | Straight steel partition with perforated window, no access |
| 1 | N5-RS48-4 | Steel shelving unit, 14" D x 48" W x 62" H |
| 1 | N5-RS72-4 | Steel shelving unit, 14" D x 72" W x 62" H |
| 1 | X50-B | Compact 2-drawer unit |
| 1 | X50-C | Compact 3-drawer unit |

PACKAGES

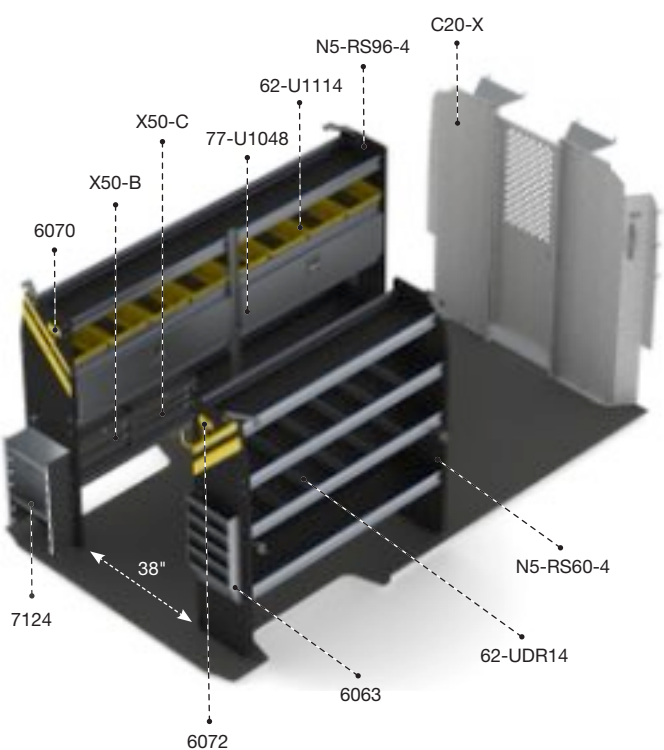

RPL-11 ELECTRICAL

| | | |
|---------|-----------------|------|
| Steel | 159", 159" Ext. | High |
| 402 lbs | 6.3 hrs | Yes |

| Qty | Part # | Description |
|-----|-----------|---------------------------------------------------------------|
| 1 | 6063 | Paper holder, extra deep, 5 slots |
| 1 | 6070 | 6" Hook, 3" opening, painted |
| 1 | 6072 | 8" Swivel hook, 4" opening, painted |
| 8 | 62-U1114 | 14" Deep plastic bin |
| 2 | 62-UDR14 | Set of 5 dividers for a 14" shelf |
| 1 | 7124 | Reel holder with two 5/8" diameter rods |
| 2 | 77-U1048 | Adjustable shelving door unit - 45" W - for 48" & 96" shelves |
| 1 | C20-X | Straight steel partition with perforated window, no access |
| 1 | N5-RS60-4 | Steel shelving unit, 14" D x 60" W x 62" H |
| 1 | N5-RS96-4 | Steel shelving unit, 14" D x 96" W x 62" H |
| 1 | X50-B | Compact 2-drawer unit |
| 1 | X50-C | Compact 3-drawer unit |



RAM PROMASTER

PACKAGES

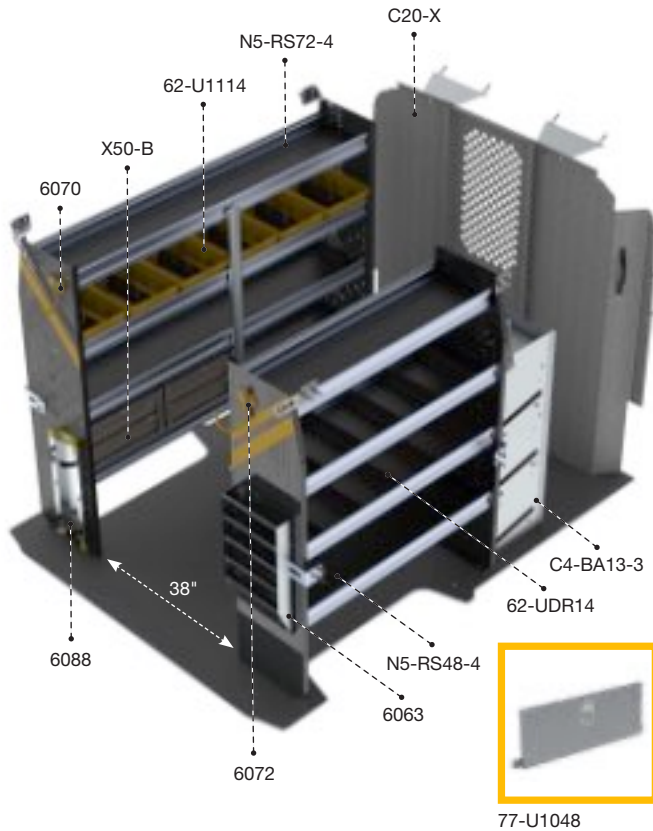

RPS-12 HVAC

| | | | | | |
|--|---------|--|------------|--|------------|
| | Steel | | 118", 136" | | Low / High |
| | 376 lbs | | 6.1 hrs | | Yes |

| Qty | Part # | Description |
|-----|------------------|--------------------------------------------------------------|
| 1 | C4-BA13-3 | 3 Tier refrigerant rack for large bottles |
| 1 | 6063 | Paper holder, extra deep, 5 slots |
| 1 | 6070 | 6" Hook, 3" opening, painted |
| 1 | 6072 | 8" Swivel hook, 4" opening, painted |
| 1 | 6088 | Large aluminum bottle holder, with two black nylon straps |
| 6 | 62-U1114 | 14" Deep plastic bin |
| 2 | 62-UDR14 | Set of 5 dividers for a 14" shelf |
| 1 | 77-U1048 | Adjustable shelving door unit - 45" W - for 48" & 96"shelves |
| 1 | C20-X | Straight steel partition with perforated window, no access |
| 1 | N5-RS48-4 | Steel shelving unit, 14" D x 48" W x 62" H |
| 1 | N5-RS72-4 | Steel shelving unit, 14" D x 72" W x 62" H |
| 2 | X50-B | Compact 2-drawer unit |

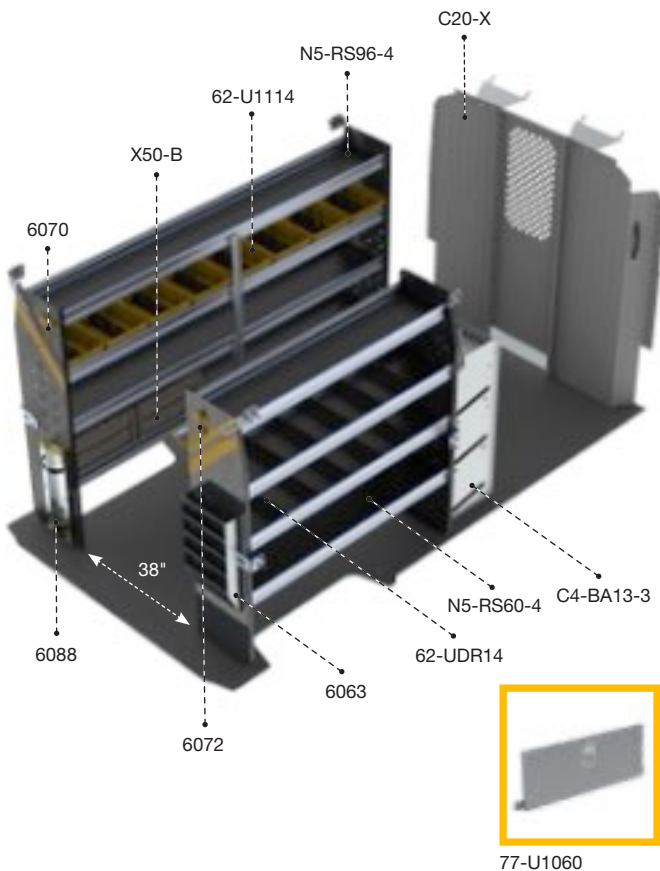

RPL-12 HVAC

| | | | | | |
|--|---------|--|-----------------|--|------|
| | Steel | | 159", 159" Ext. | | High |
| | 412 lbs | | 6.1 hrs | | Yes |

| Qty | Part # | Description |
|-----|------------------|------------------------------------------------------------|
| 1 | C4-BA13-3 | 3 Tier refrigerant rack for large bottles |
| 1 | 6063 | Paper holder, extra deep, 5 slots |
| 1 | 6070 | 6" Hook, 3" opening, painted |
| 1 | 6072 | 8" Swivel hook, 4" opening, painted |
| 1 | 6088 | Large aluminum bottle holder, with two black nylon straps |
| 8 | 62-U1114 | 14" Deep plastic bin |
| 2 | 62-UDR14 | Set of 5 dividers for a 14" shelf |
| 1 | 77-U1060 | Adjustable shelving door unit - 57" W - for 60" shelves |
| 1 | C20-X | Straight steel partition with perforated window, no access |
| 1 | N5-RS60-4 | Steel shelving unit, 14" D x 60" W x 62" H |
| 1 | N5-RS96-4 | Steel shelving unit, 14" D x 96" W x 62" H |
| 2 | X50-B | Compact 2-drawer unit |



SERVICE **RPS-16**

RAM **PROMASTER**





RAM PROMASTER

PACKAGES

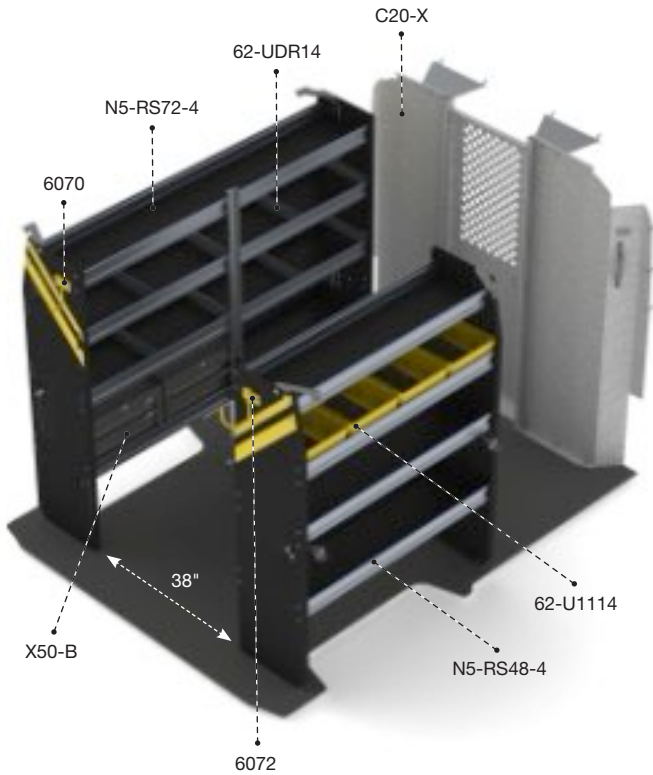

RPS-16 SERVICE

| | | | | | |
|--|---------|--|------------|--|------------|
| | Steel | | 118", 136" | | Low / High |
| | 326 lbs | | 4.6 hrs | | Yes |

| Qty | Part # | Description |
|-----|-----------|------------------------------------------------------------|
| 1 | 6070 | 6" Hook, 3" opening, painted |
| 1 | 6072 | 8" Swivel hook, 4" opening, painted |
| 4 | 62-U1114 | 14" Deep plastic bin |
| 2 | 62-UDR14 | Set of 5 dividers for a 14" shelf |
| 1 | C20-X | Straight steel partition with perforated window, no access |
| 1 | N5-RS48-4 | Steel shelving unit, 14" D x 48" W x 62" H |
| 1 | N5-RS72-4 | Steel shelving unit, 14" D x 72" W x 62" H |
| 2 | X50-B | Compact 2-drawer unit |

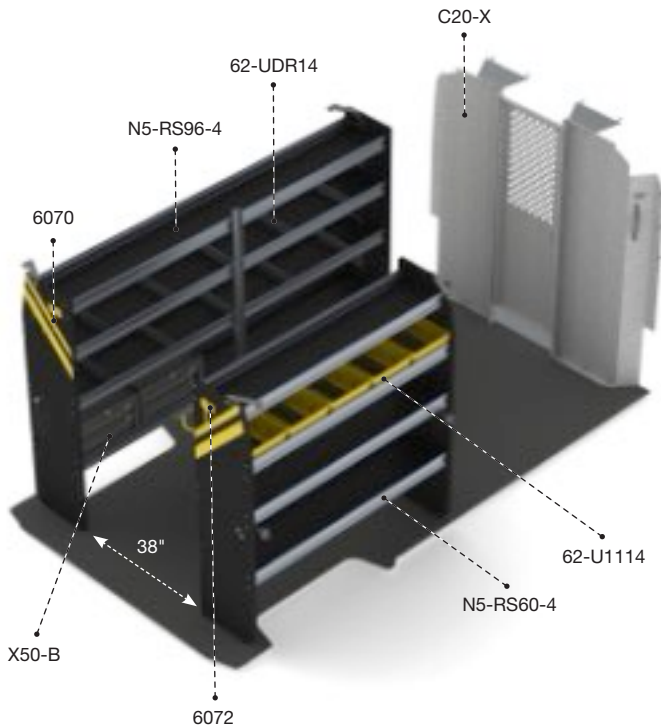

RPL-16 SERVICE

| | | | | | |
|--|---------|--|-----------------|--|------|
| | Steel | | 159", 159" Ext. | | High |
| | 359 lbs | | 4.6 hrs | | Yes |

| Qty | Part # | Description |
|-----|-----------|------------------------------------------------------------|
| 1 | 6070 | 6" Hook, 3" opening, painted |
| 1 | 6072 | 8" Swivel hook, 4" opening, painted |
| 5 | 62-U1114 | 14" Deep plastic bin |
| 2 | 62-UDR14 | Set of 5 dividers for a 14" shelf |
| 1 | C20-X | Straight steel partition with perforated window, no access |
| 1 | N5-RS60-4 | Steel shelving unit, 14" D x 60" W x 62" H |
| 1 | N5-RS96-4 | Steel shelving unit, 14" D x 96" W x 62" H |
| 2 | X50-B | Compact 2-drawer unit |



RAM PROMASTER

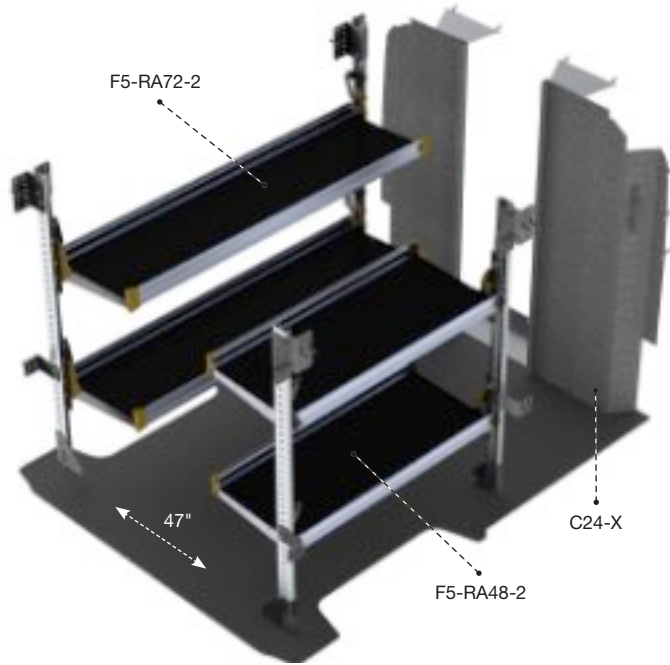

RPS-19
DELIVERY

| | | |
|----------|------------|------------|
| Aluminum | 118", 136" | Low / High |
| 228 lbs | 4.2 hrs | Yes |

| Qty | Part # | Description |
|-----|-----------|-------------------------------------------------|
| 1 | C24-X | Straight walk through steel partition |
| 1 | F5-RA72-2 | Fold-away unit, 2 levels, 25" D x 72" W x 63" H |
| 1 | F5-RA48-2 | Fold-away unit, 2 levels, 25" D x 48" W x 63" H |

PACKAGES

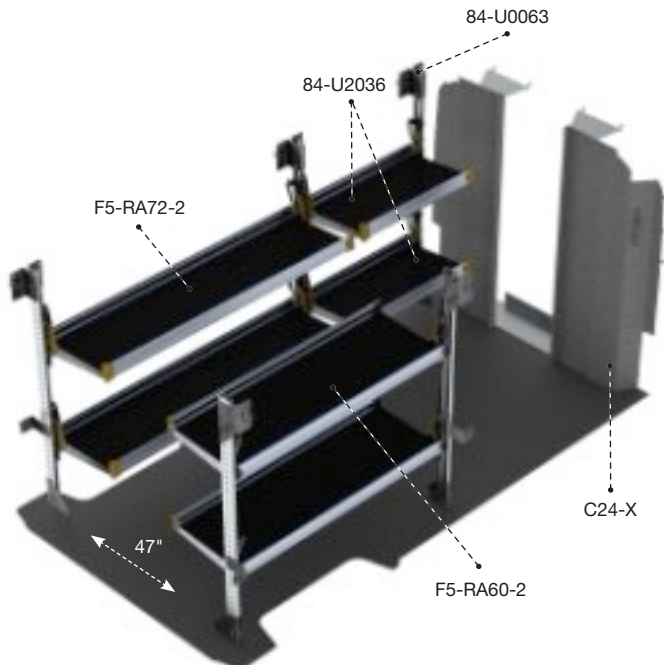

RPL-19
DELIVERY

| | | |
|----------|-----------------|------|
| Aluminum | 159", 159" Ext. | High |
| 289 lbs | 5.3 hrs | Yes |

| Qty | Part # | Description |
|-----|-----------|-------------------------------------------------|
| 1 | C24-X | Straight walk through partition |
| 1 | F5-RA60-2 | Fold-away unit, 2 levels, 25" D x 60" W x 63" H |
| 1 | F5-RA72-2 | Fold-away unit, 2 levels, 25" D x 72" W x 63" H |
| 1 | 84-U0063 | Post assembly for fold-away shelving, 63" |
| 2 | 84-U2036 | Fold-away shelf tray, 20" D x 36" W |



RAM PROMASTER

PACKAGES

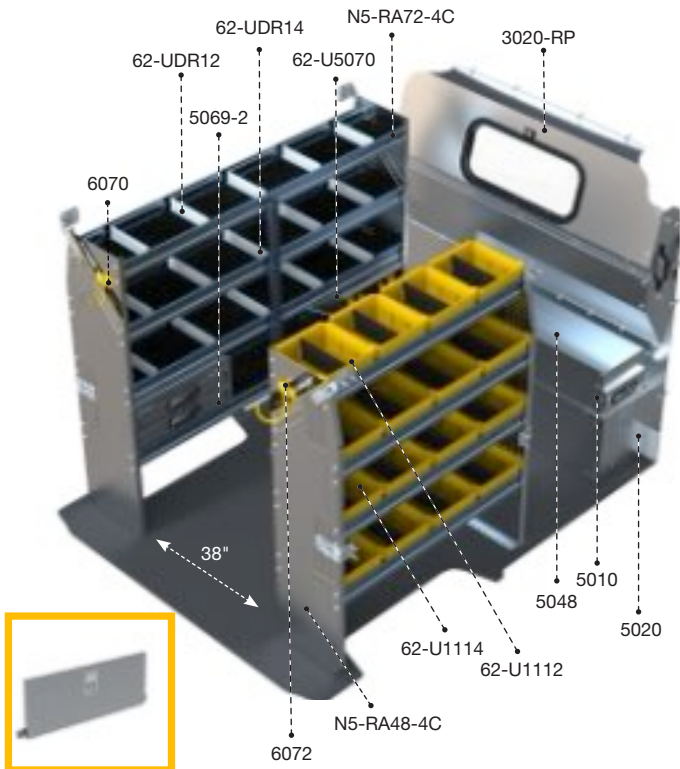

77-U1048

RPS-27 ALUMINUM

| | | | | | |
|--|----------|--|------------|--|------------|
| | Aluminum | | 118", 136" | | Low / High |
| | 386 lbs | | 7.3 hrs | | Yes |

| Qty | Part # | Description |
|-----|-------------------|---------------------------------------------------------------|
| 1 | 3020-RP | Countoured safety partition with glass window |
| 1 | 5010 | Partslider 48" D |
| 1 | 5020 | Tool drawer 48" D x 14" W x 16" H |
| 1 | 5048 | Top edge |
| 1 | 5069-2 | 2 Drawer cabinet |
| 2 | 62-U5070 | Partskeeper carry case with holder |
| 1 | 6070 | 6" Hook, 3" opening, painted |
| 1 | 6072 | 8" Swivel hook, 4" opening, painted |
| 4 | 62-U1112 | 12" Deep plastic bin |
| 12 | 62-U1114 | 14" Deep plastic bin |
| 1 | 62-UDR12 | Set of 5 dividers for a 12" shelf |
| 2 | 62-UDR14 | Set of 5 dividers for a 14" shelf |
| 1 | 77-U1048 | Adjustable shelving door unit - 45" W - for 48" & 96" shelves |
| 1 | N5-RA48-4C | Composite Aluminum shelving unit, 14" D x 48" W x 62" H |
| 1 | N5-RA72-4C | Composite Aluminum shelving unit, 14" D x 72" W x 62" H |

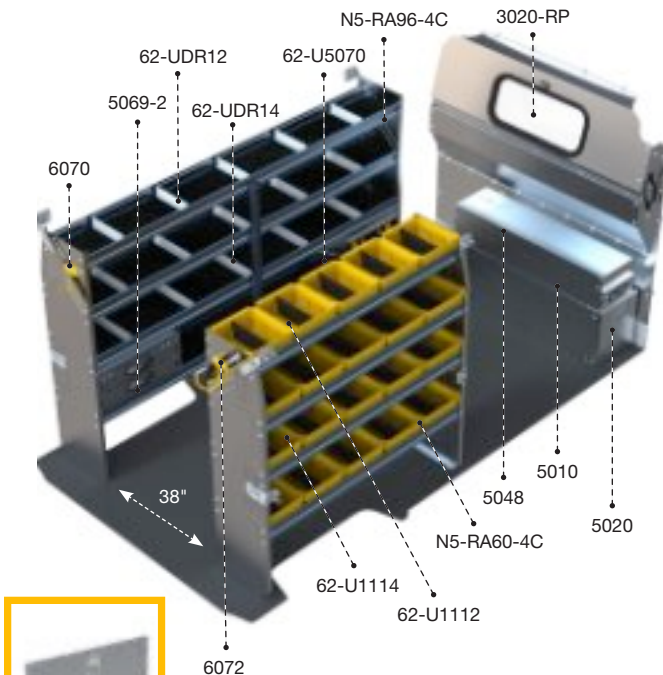

77-U1060

RPL-27 ALUMINUM

| | | | | | |
|--|----------|--|-----------------|--|------|
| | Aluminum | | 159", 159" Ext. | | High |
| | 416 lbs | | 7.3 hrs | | Yes |

| Qty | Part # | Description |
|-----|-------------------|---------------------------------------------------------|
| 1 | 3020-RP | Countoured safety partition with glass window |
| 1 | 5010 | Partslider 48" D |
| 1 | 5020 | Tool drawer 48" D x 14" W x 16" H |
| 1 | 5048 | Top edge |
| 1 | 5069-2 | 2 Drawer cabinet |
| 2 | 62-U5070 | Partskeeper carry case with holder |
| 1 | 6070 | 6" Hook, 3" opening, painted |
| 1 | 6072 | 8" Swivel hook, 4" opening, painted |
| 5 | 62-U1112 | 12" deep plastic bin |
| 15 | 62-U1114 | 14" deep plastic bin |
| 1 | 62-UDR12 | Set of 5 dividers for a 12" Shelf |
| 2 | 62-UDR14 | Set of 5 dividers for a 14" Shelf |
| 1 | 77-U1060 | Adjustable shelving door unit - 57" W - for 60" shelves |
| 1 | N5-RA60-4C | Composite Aluminum Shelving unit, 14" D x 60" W x 62" H |
| 1 | N5-RA96-4C | Composite Aluminum Shelving unit, 14" D x 96" W x 62" H |



RAM **PROMASTER CITY**

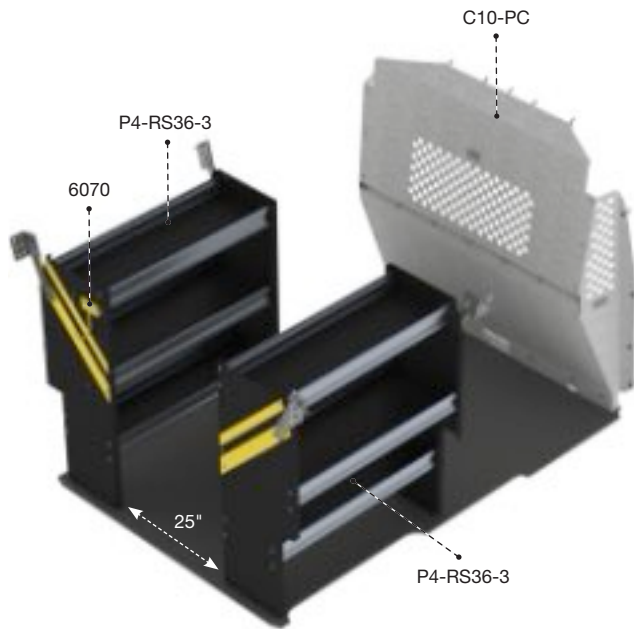

PMC-10
CONTRACTOR

| | | |
|---------|---------|----------|
| Steel | 122" | Standard |
| 156 lbs | 3.2 hrs | Yes |

| Qty | Part # | Description |
|-----|-----------|--------------------------------------------------|
| 1 | 6070 | 6" Hook, 3" opening, painted |
| 1 | C10-PC | Contoured steel partition with perforated window |
| 2 | P4-RS36-3 | Steel shelving unit, 14" D x 36" W x 42" H |

PACKAGES

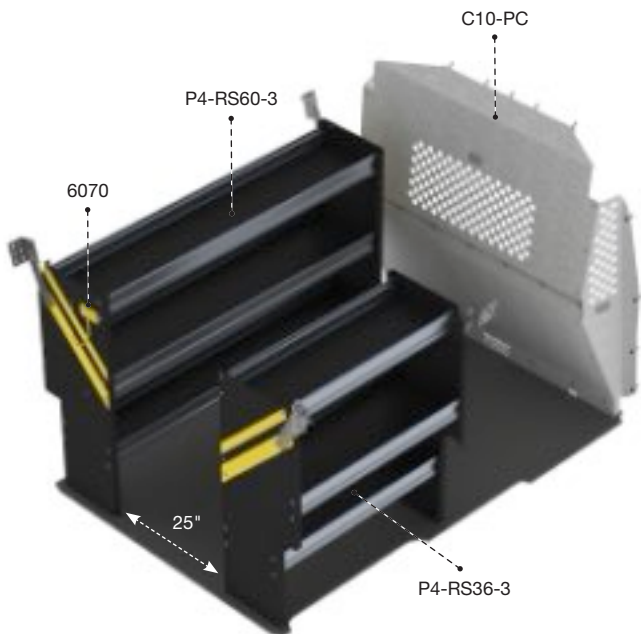

PMD-10
CONTRACTOR

| | | |
|---------|---------|----------|
| Steel | 122" | Standard |
| 170 lbs | 3.2 hrs | Yes |

| Qty | Part # | Description |
|-----|-----------|--------------------------------------------------|
| 1 | 6070 | 6" Hook, 3" opening, painted |
| 1 | C10-PC | Contoured steel partition with perforated window |
| 1 | P4-RS36-3 | Steel shelving unit, 14" D x 36" W x 42" H |
| 1 | P4-RS60-3 | Steel shelving unit, 14" D x 60" W x 42" H |



RAM PROMASTER CITY

PACKAGES

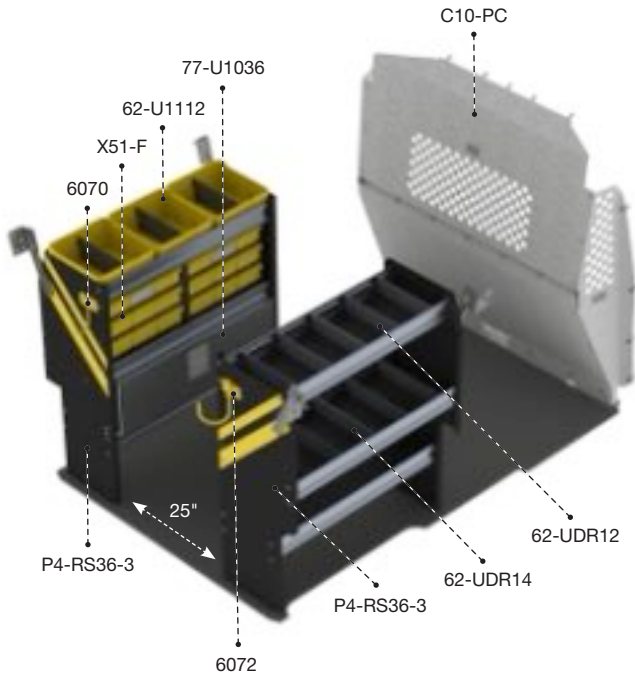

PMC-11 ELECTRICAL

| | | |
|---------|---------|----------|
| Steel | 122" | Standard |
| 230 lbs | 4.5 hrs | Yes |

| Qty | Part # | Description |
|-----|-----------|---------------------------------------------------------------|
| 1 | 6070 | 6" Hook, 3" opening, painted |
| 1 | 6072 | 8" Swivel hook, 4" opening, painted |
| 3 | 62-U1112 | 12" Deep plastic bin |
| 1 | 62-UDR12 | Set of 5 dividers for a 12" shelf |
| 1 | 62-UDR14 | Set of 5 dividers for a 14" shelf |
| 1 | 77-U1036 | Adjustable shelving door unit - 33" W - for 36" & 72" shelves |
| 1 | C10-PC | Contoured steel partition with perforated window |
| 2 | P4-RS36-3 | Steel shelving units, 14" D x 36" H x 42" W |
| 2 | X51-F | Compact 9-drawer unit |

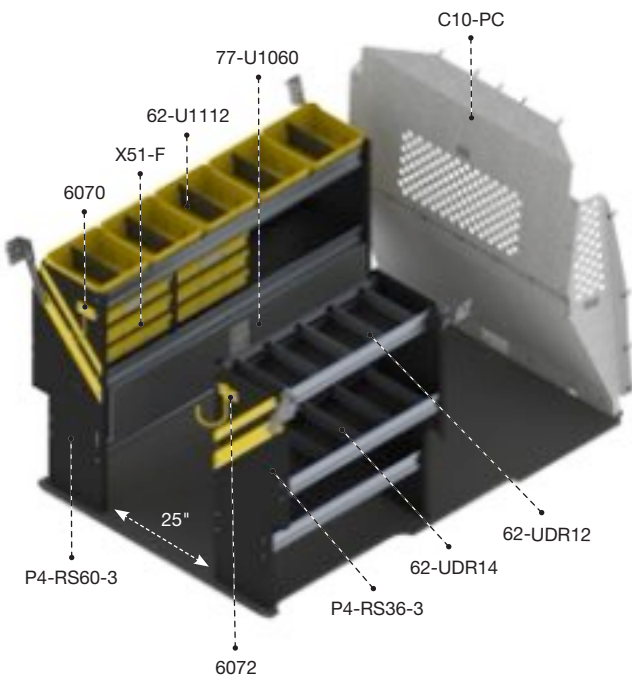

PMD-11 ELECTRICAL

| | | |
|---------|---------|----------|
| Steel | 122" | Standard |
| 251 lbs | 4.5 hrs | Yes |

| Qty | Part # | Description |
|-----|-----------|---------------------------------------------------------|
| 1 | 6070 | 6" Hook, 3" opening, painted |
| 1 | 6072 | 8" Swivel hook, 4" opening, painted |
| 5 | 62-U1112 | 12" Deep plastic bin |
| 1 | 62-UDR12 | Set of 5 dividers for a 12" shelf |
| 1 | 62-UDR14 | Set of 5 dividers for a 14" shelf |
| 1 | 77-U1060 | Adjustable shelving door unit - 57" W - for 60" shelves |
| 1 | C10-PC | Contoured steel partition with perforated window |
| 1 | P4-RS36-3 | Steel shelving unit, 14" D x 36" H x 42" W |
| 1 | P4-RS60-3 | Steel shelving unit, 14" D x 60" H x 42" W |
| 2 | X51-F | Compact 9-drawer unit |



RAM PROMASTER CITY

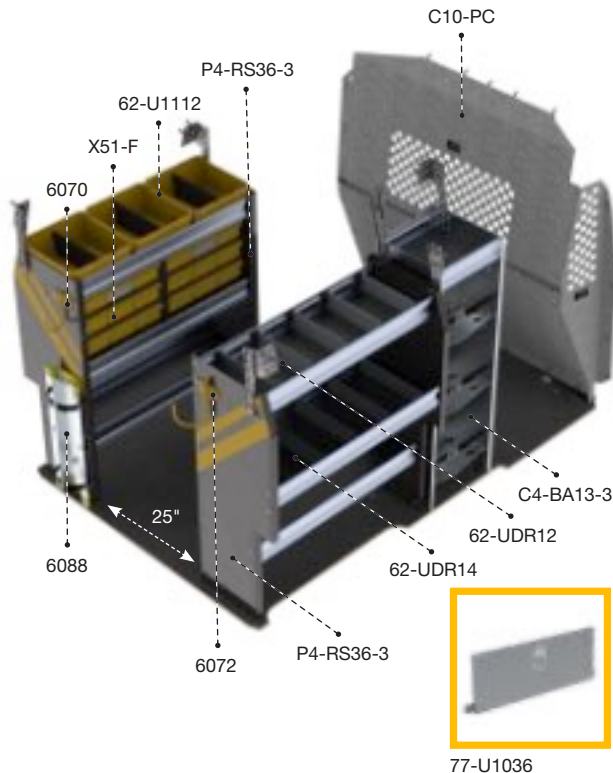

PMC-12

HVAC

| | | |
|---------|---------|----------|
| Steel | 122" | Standard |
| 260 lbs | 5.3 hrs | Yes |

| Qty | Part # | Description |
|-----|-----------|---------------------------------------------------------------|
| 1 | C4-BA13-3 | 3 Tier refrigerant rack for large bottles |
| 1 | 6070 | 6" Hook, 3" opening, painted |
| 1 | 6072 | 8" Swivel hook, 4" opening, painted |
| 1 | 6088 | Large aluminum bottle holder, with two black nylon straps |
| 3 | 62-U1112 | 12" Deep plastic bin |
| 1 | 62-UDR12 | Set of 5 dividers for a 12" shelf |
| 1 | 62-UDR14 | Set of 5 dividers for a 14" shelf |
| 1 | 77-U1036 | Adjustable shelving door unit - 33" W - for 36" & 72" shelves |
| 1 | C10-PC | Contoured steel partition with perforated window |
| 2 | P4-RS36-3 | Steel shelving units, 14" D x 36" W x 42" H |
| 2 | X51-F | Compact 9-drawer unit |

PACKAGES

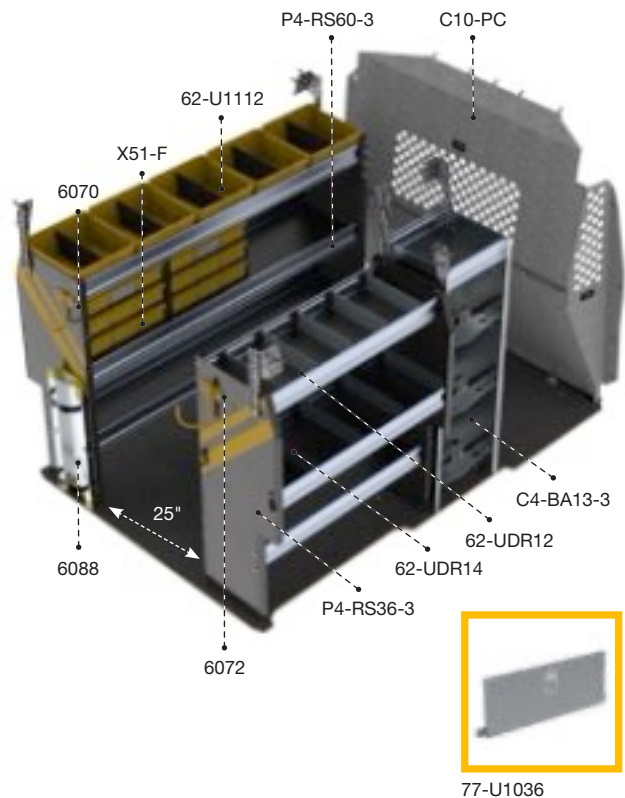

PMD-12

HVAC

| | | |
|---------|---------|----------|
| Steel | 122" | Standard |
| 278 lbs | 5.3 hrs | Yes |

| Qty | Part # | Description |
|-----|-----------|---------------------------------------------------------------|
| 1 | C4-BA13-3 | 3 Tier refrigerant rack for large bottles |
| 1 | 6070 | 6" Hook, 3" opening, painted |
| 1 | 6072 | 8" Swivel hook, 4" opening, painted |
| 1 | 6088 | Large aluminum bottle holder, with two black nylon straps |
| 5 | 62-U1112 | 12" Deep plastic bin |
| 1 | 62-UDR12 | Set of 5 dividers for a 12" shelf |
| 1 | 62-UDR14 | Set of 5 dividers for a 14" shelf |
| 1 | 77-U1036 | Adjustable shelving door unit - 33" W - for 36" & 72" shelves |
| 1 | C10-PC | Contoured steel partition with perforated window |
| 1 | P4-RS36-3 | Steel shelving unit, 14" D x 36" W x 42" H |
| 1 | P4-RS60-3 | Steel shelving unit, 14" D x 60" W x 42" H |
| 2 | X51-F | Compact 9-drawer unit |



SERVICE
PMC-16

RAM **PROMASTER CITY**





RAM **PROMASTER CITY**

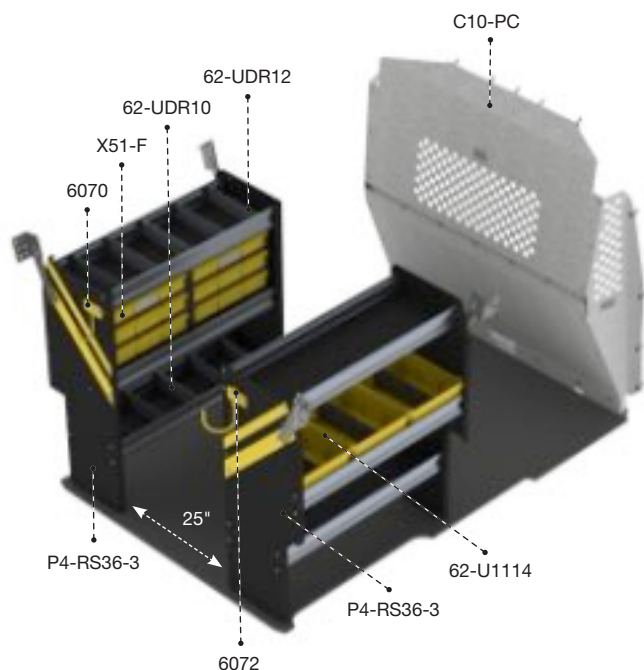

PMC-16

SERVICE

| | | |
|---------|-------|----------|
| Steel | 122" | Standard |
| 223 lbs | 4 hrs | Yes |

| Qty | Part # | Description |
|-----|-----------|--------------------------------------------------|
| 1 | 6070 | 6" Hook, 3" opening, painted |
| 1 | 6072 | 8" Swivel hook, 4" opening, painted |
| 3 | 62-U1114 | 14" Deep plastic bin |
| 1 | 62-UDR10 | Set of 5 dividers for a 10" shelf |
| 1 | 62-UDR12 | Set of 5 dividers for a 12" shelf |
| 1 | C10-PC | Contoured steel partition with perforated window |
| 2 | P4-RS36-3 | Steel shelving units, 14" D x 36" W x 42" H |
| 2 | X51-F | Compact 9-drawer unit |

PACKAGES

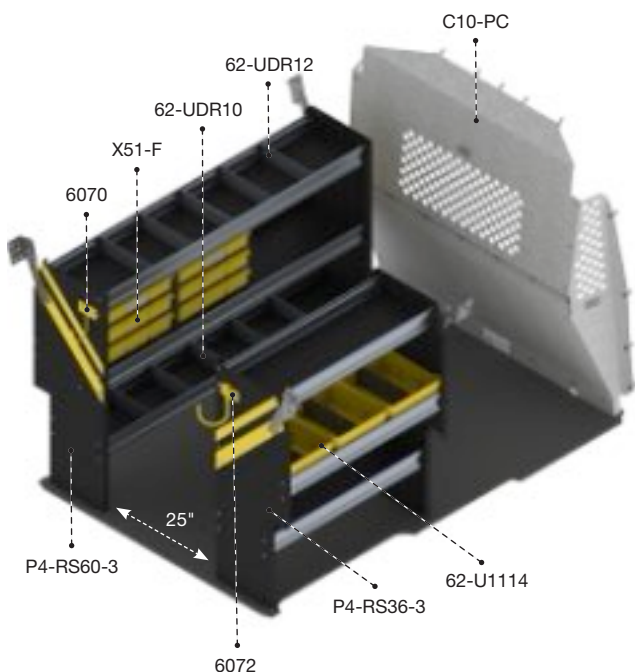

PMD-16

SERVICE

| | | |
|---------|-------|----------|
| Steel | 122" | Standard |
| 237 lbs | 4 hrs | Yes |

| Qty | Part # | Description |
|-----|-----------|--------------------------------------------------|
| 1 | 6070 | 6" Hook, 3" opening, painted |
| 1 | 6072 | 8" Swivel hook, 4" opening, painted |
| 3 | 62-U1114 | 14" Deep plastic bin |
| 1 | 62-UDR10 | Set of 5 dividers for a 10" shelf |
| 1 | 62-UDR12 | Set of 5 dividers for a 12" shelf |
| 1 | C10-PC | Contoured steel partition with perforated window |
| 1 | P4-RS36-3 | Steel shelving unit, 14" D x 36" W x 42" H |
| 1 | P4-RS60-3 | Steel shelving unit, 14" D x 60" W x 42" H |
| 2 | X51-F | Compact 9-drawer unit |

RAM PROMASTER CITY



PACKAGES

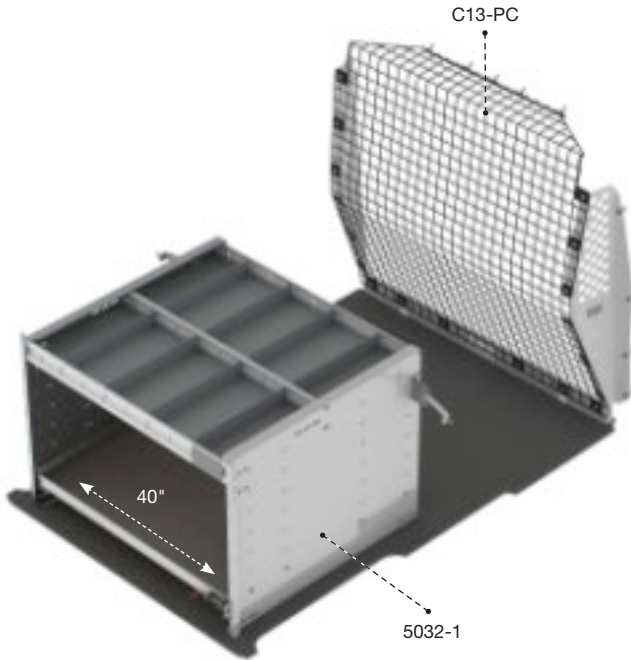

PMC-19 DELIVERY

| | | |
|----------|-------|----------|
| Aluminum | 122" | Standard |
| 161 lbs | 2 hrs | Yes |

| Qty | Part # | Description |
|-----|---------------|-------------------------------------------------------------|
| 1 | 5032-1 | Axess tray with 1 shelf and 1 drawer, 38" D x 45" W x 30" H |
| 1 | C13-PC | Wire mesh partition, 38" D x 45" W x 30" H |

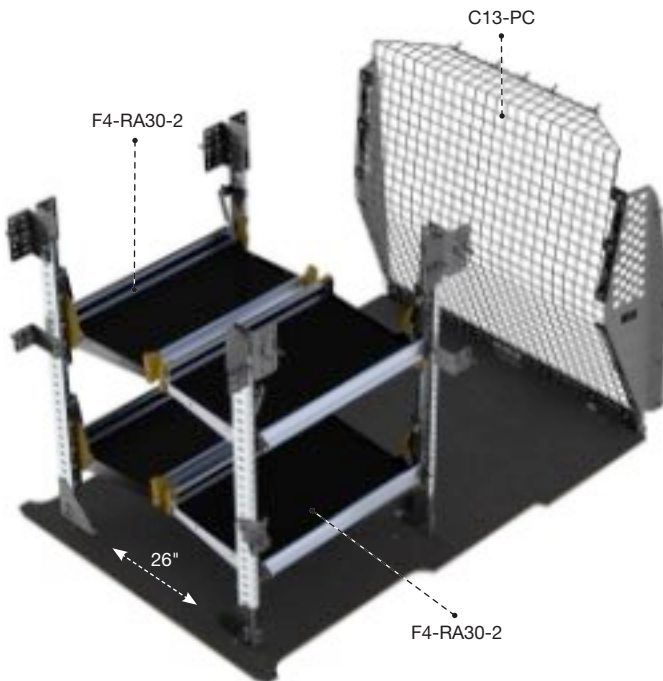

PMD-19 DELIVERY

| | | |
|----------|---------|----------|
| Aluminum | 122" | Standard |
| 188 lbs | 4.2 hrs | Yes |

| Qty | Part # | Description |
|-----|------------------|-------------------------------------------------|
| 1 | C13-PC | Wire mesh partition |
| 2 | F4-RA30-2 | Fold-away unit, 2 levels, 22" D x 30" W x 47" H |



DELIVERY PMD-19

RAM **PROMASTER CITY**



LEGEND



Wheelbase



Roof Height



Weight



Estimated Install Time



Quickship